



**Bayblend<sup>®</sup>** –  
the polycarbonate blend

**Product range – typical values – properties – processing**





## Bayblend®

Bayblend® is the trade name used by Bayer MaterialScience AG for its product line of amorphous, thermoplastic polymer blends based on polycarbonate (PC) and acrylonitrile butadiene styrene copolymer (ABS) as well as the rubber-modified polycarbonate (PC) and styrene-acrylonitrile copolymer (SAN) blends.

The Bayblend® product range comprises:

- Nonreinforced standard grades (T grades)
- Nonreinforced flame-retardant grades (FR grades)
- Mineral-filled grades
- Glass fiber-reinforced T grades
- Special-purpose grades for specific applications



## PROPERTIES

Characteristic features:

- High impact and notched impact strength
- High stiffness
- Heat resistant to 142 °C as per Vicat VST/B 120
- High dimensional accuracy and stability
- Low tendency to warp
- Low overall shrinkage
- Good light stability
- Good processing properties
- No juicing/plate-out with FR grades
- Antimony-, chlorine- and bromine-free flame-retardant FR grades
- FR grades fulfill the glow wire test requirements according to IEC 60331-1 (domestic appliances [GWFI min. 850 °C, GWIT min. 775 °C from 1.5 mm])

## APPLICATIONS

The main areas of application for Bayblend® are:

- Automotive
- Data and information technology industries
- Electrical/electronic
- Household, leisure, sports

## DELIVERY FORM

The products are supplied in the form of oval, spherical or cylindrical granules in 25-kg polyethylene sacks, in large cartons with a PE liner, in big bags or by silo truck.

The Bayblend® grades are available in natural color or opaque with a wide range of shades.

The production plants for Bayblend® in Europe, Asia and the USA have been certified to ISO 9001:2008 by the DQS (German Association for the Certification of Quality Systems, Berlin). The certificates can be viewed at <http://www.bayermaterialscience.com> (Customer Services/Certificates/Quality).

# Bayblend® – Product range

## GENERAL PURPOSE GRADES

### Nonreinforced

#### T45 PG

Injection molding grade; Vicat/B 120 = 112 °C; for electroplating applications

#### T65

Injection molding grade; Vicat/B 120 = 120 °C; good low-temperature impact strength

#### T85

Injection molding grade; Vicat/B 120 = 131 °C; high impact and notched impact strength

#### T50 XF

Injection molding grade; Vicat/B 120 = 115 °C; particularly good flow; good low-temperature impact strength

#### T65 XF

Injection molding grade; Vicat/B 120 = 120 °C; better flow than T65

#### T85 XF

Injection molding grade; Vicat/B 120 = 130 °C; better flow than T85

#### T65 HI

Grade with improved low-temperature impact strength and chemical resistance for automotive parts; also suitable for extrusion/extrusion blow molding and electroplating applications; Vicat/B 120 temperature = 120 °C

#### T80 XG

Injection molding grade; Vicat/B 120 temperature = 127 °C; excellent flow; optimized surface quality for metallization (steam treatment)

#### T90

Injection molding grade; Vicat/B 120 = 127 °C; particularly good flow

#### T90 HT

Injection molding grade; good heat resistance; Vicat/B 120 = 135 °C; ball indentation temperature  $\geq$  125 °C; good flow; suitable for use with current-carrying components

#### W85 XF

(PC+ASA) blend; injection molding grade; improved weather resistance; improved heat aging stability; good heat resistance; Vicat/B 120 = 132 °C



### Glass fiber-reinforced

#### T88 GF-10

Injection molding grade; 10 % GF; optimized heat aging and UV stability; very good flow; tensile modulus = 5100 MPa; Vicat/B 120 = 134 °C

#### T88 GF-20

Injection molding grade; 20 % GF; optimized heat aging and UV stability; very good flow; tensile modulus = 7500 MPa; Vicat/B 120 = 130 °C

#### T88 GF-30

Injection molding grade; 31 % GF; optimized heat ageing- and UV-stability; very good flow; tensile modulus = 10000 MPa; Vicat/B 120 = 134 °C

### Mineral-filled

#### T95 MF

Injection molding grade; 9 % mineral-filled; very good heat resistance; reduced coefficient of expansion; tensile modulus = 3350 MPa; Vicat/B 120 = 142 °C

#### T90 MF-20

Injection molding grade; 20 % mineral-filled; very good flow; reduced coefficient of expansion; tensile modulus = 5200 MPa; Vicat/B 120 = 130 °C

#### ET 1100

Extrusion grade; 10 % mineral-filled; very good heat resistance; Vicat/B 120 = 142 °C; reduced coefficient of expansion; tensile modulus = 3300 MPa



## FLAME-RETARDANT GRADES

### Nonreinforced

#### FR 3000

Injection molding grade; easy-flow grade; Vicat/B 120 temperature = 97 °C; UL recognition 94 V-0 (1.5 mm); glow wire test (GWFI): 960 °C (2.0 mm); no juicing; good light stability

#### FR 3000 HI

Injection molding grade; general purpose; compared to FR 3000 improved chemical resistance and stress cracking behavior; Vicat/B 120 temperature = 97 °C; UL recognition 94 V-0 at 1.5 mm

#### FR 3002

Injection molding grade; for notebooks and thinwall applications; Vicat/B 120 temperature = 99 °C; UL recognition 94 V-0 (1.2 mm); glow wire test (GWFI): 960 °C (2.0 mm); no juicing

#### FR 3005

Injection molding grade; easy-flow grade; Vicat/B 120 temperature = 95 °C; UL recognition 94 V-0 (1.5 mm); glow wire test (GWFI): 960 °C (2.0 mm); no juicing; good light stability

#### FR 3005 HF

Injection molding grade; very easy-flow grade; Vicat/B 120 temperature = 96 °C; UL recognition 94 V-0 (1.5 mm)

#### FR 3006

Injection molding grade; high heat resistance; Vicat/B 120 = 110 °C; easy flow; UL recognition 94 V-1 at 1.5 mm and V-0 at 2.0 mm

#### FR 3008

Injection molding grade; HDT/A  $\geq$  85 °C; Vicat/B 120 temperature = 103 °C; UL recognition 94 V-0 (1.5 mm); improved chemical and hydrolysis resistance; glow wire test (GWFI): 960 °C (2.0 mm); no juicing; good light stability

#### FR 3008 HR

Injection molding grade; HDT/A  $\geq$  85 °C; Vicat/B 120 temperature = 103 °C; UL recognition 94 V-0 (1.5 mm); improved chemical and very good hydrolysis resistance; glow wire test (GWFI): 960 °C (2.0 mm); no juicing; good light stability

#### FR 3010

Injection molding grade; increased heat resistance; Vicat/B 120 temperature = 110 °C; UL recognition 94 V-0 (1.5 mm); glow wire test (GWFI): 960 °C (2.0 mm); improved chemical resistance and stress cracking behavior; successor to FR 2010

#### FR 3010 IF

Injection molding grade; increased heat resistance; Vicat/B 120 temperature = 108 °C; improved flammability; UL recognition 94 5VB (1.5 mm); glow wire test (GWFI): 960 °C (2.0 mm); improved flow compared to FR 3010

#### FR 3011

Injection molding grade; good flow; high heat resistance; Vicat/B 120 temperature = 118 °C; UL recognition 94 V-0 (1.5 mm); glow wire test (GWFI): 960 °C (2.0 mm); no juicing; good light stability

#### FR 3030

Flame retardant extrusion grade; Vicat/B 120 temperature = 115 °C; good extrusion and vacuum-forming behaviour; UL recognition 94 V-0 (1.5 mm); halogen-free according to DIN VDE 0472,815; glow wire temperature (GWFI): 960 °C at 2.0 mm

#### FR 3100 TV

Injection molding grade; high heat resistance; Vicat/B 120 = 110 °C; improved impact strength and chemical resistance; apply for UL recognition 94 V-1 at 1.5 mm and V-0 at 2.0 mm

#### FR 3110 TV

Injection molding grade; high heat resistance; Vicat/B 120 = 110 °C; easy flow; UL 94 V-1 at 1.5 mm and V-0 at 2.0 mm (Bayer internal test)

#### KU 2-1514

High heat resistant injection molding grade; ball indentation temperature  $\geq$  125 °C; Vicat/B 120 temperature = 136 °C; UL recognition 94 V-0 at 1.5 mm; suitable for supporting life components

#### KU 2-1514 BBS073

High heat resistant injection molding grade; improved chemical resistance and stress cracking behavior compared to KU 2-1514; ball indentation temperature  $\geq$  125 °C; Vicat/B 120 temperature = 136 °C; UL recognition 94 V-0 at 1.5 mm; suitable for supporting life components

### Mineral-filled

#### ET 3032 FR

Flame retardant extrusion grade; 10 % mineral filled; Vicat/B 120 temperature = 108 °C; good extrusion and vacuum-forming behaviour; UL recognition 94 V-0 (0.75 mm); halogen-free according to DIN VDE 0472,815; glow wire temperature (GWFI): 960 °C at 2.0 mm

#### FR 410 MT

10 % mineral filled; injection molding; Vicat/B 120 = 108 °C; very good UL recognition in small wallthickness (V-0 at 0.75 mm); for railway interiors. The classifications according to the respective rail standards are communicated with email inquiry under pcs-info@bayermaterialscience.com

#### FR 3020

5 % mineral filled; for thin-wall applications; injection molding; Vicat/B 120 = 103 °C; HDT/A  $\geq$  85 °C; very good UL recognition in small wallthickness (V-0 at 0.75 mm)

#### FR 3021

15 % mineral filled; injection molding grade; increased stiffness; tensile modulus = 4800 MPa; Vicat/B 120 temperature = 98 °C; UL recognition 94 V-0 (1.5 mm); glow wire test (GWFI): 960 °C (2.0 mm); no juicing



# Bayblend® – typical values

				Standard grades				
				Non reinforced				
Properties	Test conditions	Units	Standards	T45 PG	T65	T85	T50 XF	T65 XF
<b>Rheological properties</b>								
Melt viscosity <sup>1)</sup>	260 °C; 1000 s <sup>-1</sup>	Pas	b. o. ISO 11443-A	200	230	290	190	200
<b>C</b> Melt volume-flow rate (MVR)	240 °C; 5 kg	cm <sup>3</sup> /10 min	ISO 1133					
<b>C</b> Melt volume-flow rate (MVR)	260 °C; 5 kg	cm <sup>3</sup> /10 min	ISO 1133	12	12	12	26	18
Molding shrinkage, parallel	150 x 105 x 3 mm; 240 °C / mold 80 °C	%	b. o. ISO 2577					
Molding shrinkage, parallel	150 x 105 x 3 mm; 260 °C / mold 80 °C	%	b. o. ISO 2577	0.55 – 0.75	0.55 – 0.75	0.55 – 0.75	0.55 – 0.75	0.5 – 0.7
Molding shrinkage, normal	150 x 105 x 3 mm; 240 °C / mold 80 °C	%	b. o. ISO 2577					
Molding shrinkage, normal	150 x 105 x 3 mm; 260 °C / mold 80 °C	%	b. o. ISO 2577	0.55 – 0.75	0.55 – 0.75	0.55 – 0.75	0.55 – 0.75	0.5 – 0.7
<b>Mechanical properties (23 °C / 50 % r. h.)</b>								
<b>C</b> Tensile modulus	1 mm/min	MPa	ISO 527-1,-2	2100	2200	2300	2200	2400
<b>C</b> Tensile yield stress	50 mm/min	MPa	ISO 527-1,-2	49	52	55	50	54
<b>C</b> Tensile yield strain	50 mm/min	%	ISO 527-1,-2	3.7	4.2	4.7	4.5	4.4
Tensile stress at break	50 mm/min	MPa	ISO 527-1,-2	40	45	48	48	47
Tensile strain at break	50 mm/min	%	b. o. ISO 527-1,-2	> 50	> 50	> 50	> 50	> 50
Tensile yield stress	5 mm/min	MPa	ISO 527-1,-2					
Tensile yield strain	5 mm/min	%	ISO 527-1,-2					
<b>C</b> Tensile stress at break	5 mm/min	MPa	ISO 527-1,-2					
<b>C</b> Tensile strain at break	5 mm/min	%	ISO 527-1,-2					
Izod impact strength	23 °C	kJ/m <sup>2</sup>	ISO 180/U	N	N	N	N	N
Izod impact strength	-30 °C	kJ/m <sup>2</sup>	ISO 180/U	N	N	N	N	N
Izod notched impact strength	23 °C	kJ/m <sup>2</sup>	ISO 180/A	40	45	48	45	45
Izod notched impact strength	-20 °C	kJ/m <sup>2</sup>	ISO 180/A					
Izod notched impact strength	-30 °C	kJ/m <sup>2</sup>	ISO 180/A	36	41	38	38	35
<b>Thermal properties</b>								
<b>C</b> Temperature of deflection under load	1,80 MPa	°C	ISO 75-1,-2	95	100	109	97	102
<b>C</b> Temperature of deflection under load	0,45 MPa	°C	ISO 75-1,-2	112	122	127	116	122
<b>C</b> Vicat softening temperature	50 N; 50 °C/h	°C	ISO 306	110	118	129	113	118
Vicat softening temperature	50 N; 120 °C/h	°C	ISO 306	112	120	131	115	120
<b>C</b> Coefficient of linear thermal expansion, parallel	23 to 55 °C	10 <sup>-4</sup> /K	ISO 11359-1,-2	0.85	0.8	0.75	0.9	0.8
<b>C</b> Coefficient of linear thermal expansion, normal	23 to 55 °C	10 <sup>-4</sup> /K	ISO 11359-1,-2	0.9	0.85	0.8	0.9	0.85
<b>C</b> Burning behavior UL 94 (wall thickness)		Class	UL 94	HB (0.85 mm)	HB (0.85 mm)	HB (0.85 mm)	HB (0.85 mm)	HB (0.85 mm)
<b>C</b> Burning behavior UL 94 (wall thickness)		Class	UL 94					
<b>C</b> Burning behavior UL 94-5V (wall thickness)		Class	UL 94					
Burning behavior UL 94-5V (wall thickness)		Class	UL 94					
<b>Electrical properties (23 °C / 50 % r. h.)</b>								
<b>C</b> Relative permittivity	100 Hz	–	IEC 60250	3.1	3.1	3.1	3.1	3.1
<b>C</b> Relative permittivity	1 MHz	–	IEC 60250	3.0	3.0	3.0	3.0	3.0
<b>C</b> Dissipation factor	100 Hz	10 <sup>-4</sup>	IEC 60250	35	30	20	20	30
<b>C</b> Dissipation factor	1 MHz	10 <sup>-4</sup>	IEC 60250	85	85	85	90	85
<b>C</b> Volume resistivity		Ohm·m	IEC 60093	1E14	1E14	1E14	1E14	1E14
<b>C</b> Surface resistivity		Ohm	IEC 60093	1E16	1E16	1E16	1E16	1E16
<b>C</b> Electrical strength	1 mm	kV/mm	IEC 60243-1	35	35	35	40	35
<b>C</b> Comparative tracking index (CTI)	Solution A	Rating	IEC 60112	275	250	225	175	250
<b>Other properties (23 °C)</b>								
<b>C</b> Water absorption (saturation value)	Water at 23 °C	%	ISO 62	0.7	0.7	0.7	0.7	0.7
<b>C</b> Water absorption (equilibrium value)	23 °C; 50 % r. h.	%	ISO 62	0.2	0.2	0.2	0.2	0.2
<b>C</b> Density	–	kg/m <sup>3</sup>	ISO 1183	1100	1130	1150	1110	1130
Glass fiber content	Method A	%	ISO 3451-1					
<b>Processing conditions for test specimens</b>								
<b>C</b> Injection molding: melt temperature	–	°C	ISO 294	260	260	260	260	260
<b>C</b> Injection molding: mold temperature	–	°C	ISO 294	80	80	80	80	80
<b>C</b> Injection molding: injection velocity	–	mm/s	ISO 294	240	240	240	240	240

**C** These property characteristics are taken from the CAMPUS® plastics data bank and are based on the international catalogue of basic data for plastics according to ISO 10350 (Plastics Acquisition and Presentation of Corporate Single-Point Data, 1993).

Impact properties:  
N = non break  
b. o. = based on  
r. h. = relative humidity

<sup>1)</sup>Determination of true viscosity using the method of representative viscosity  
<sup>2)</sup>Bayer test

				Standard grades					
				Non reinforced					
Properties	Test conditions	Units	Standards	T85 XF	T65 HI	T80 XG	T90	T90 HT	W85 XF
<b>Rheological properties</b>									
Melt viscosity <sup>1)</sup>	260 °C; 1000 s <sup>-1</sup>	Pas	b.o. ISO 11443-A	250	300	190	200	250	225
<b>C</b> Melt volume-flow rate (MVR)	240 °C; 5 kg	cm <sup>3</sup> /10 min	ISO 1133						
<b>C</b> Melt volume-flow rate (MVR)	260 °C; 5 kg	cm <sup>3</sup> /10 min	ISO 1133	19	5	27	25	26	27
Molding shrinkage, parallel	150 x 105 x 3 mm; 240 °C / mold 80 °C	%	b. o. ISO 2577						
Molding shrinkage, parallel	150 x 105 x 3 mm; 260 °C / mold 80 °C	%	b. o. ISO 2577	0.5 – 0.7	0.65 – 0.85	0.55 – 0.75	0.55 – 0.75	0.6 – 0.8	0.55 – 0.75
Molding shrinkage, normal	150 x 105 x 3 mm; 240 °C / mold 80 °C	%	b. o. ISO 2577						
Molding shrinkage, normal	150 x 105 x 3 mm; 260 °C / mold 80 °C	%	b. o. ISO 2577	0.5 – 0.7	0.65 – 0.85	0.55 – 0.75	0.55 – 0.75	0.6 – 0.8	0.55 – 0.75
<b>Mechanical properties (23 °C / 50 % r. h.)</b>									
<b>C</b> Tensile modulus	1 mm/min	MPa	ISO 527-1,-2	2300	2000	2500	2300	2400	2450
<b>C</b> Tensile yield stress	50 mm/min	MPa	ISO 527-1,-2	54	48	62	54	56	63
<b>C</b> Tensile yield strain	50 mm/min	%	ISO 527-1,-2	4.7	4.5	4.7	4.5	5.0	5.0
Tensile stress at break	50 mm/min	MPa	ISO 527-1,-2	50	46	50	45	48	62
Tensile strain at break	50 mm/min	%	b. o. ISO 527-1,-2	> 50	> 50	> 50	> 50	> 50	> 50
Tensile yield stress	5 mm/min	MPa	ISO 527-1,-2						
Tensile yield strain	5 mm/min	%	ISO 527-1,-2						
<b>C</b> Tensile stress at break	5 mm/min	MPa	ISO 527-1,-2						
<b>C</b> Tensile strain at break	5 mm/min	%	ISO 527-1,-2						
Izod impact strength	23 °C	kJ/m <sup>2</sup>	ISO 180/U	N	N	N	N	N	N
Izod impact strength	-30 °C	kJ/m <sup>2</sup>	ISO 180/U	N	N	N	N	N	N
Izod notched impact strength	23 °C	kJ/m <sup>2</sup>	ISO 180/A	48	48	42	42	44	45
Izod notched impact strength	-20 °C	kJ/m <sup>2</sup>	ISO 180/A					21	15
Izod notched impact strength	-30 °C	kJ/m <sup>2</sup>	ISO 180/A	35	38	14	20		
<b>Thermal properties</b>									
<b>C</b> Temperature of deflection under load	1,80 MPa	°C	ISO 75-1,-2	109	99	108	108		109
<b>C</b> Temperature of deflection under load	0,45 MPa	°C	ISO 75-1,-2	127	120	126	126		127
<b>C</b> Vicat softening temperature	50 N; 50 °C/h	°C	ISO 306	128	118	125	125	133	130
Vicat softening temperature	50 N; 120 °C/h	°C	ISO 306	130	120	127	127	135	132
<b>C</b> Coefficient of linear thermal expansion, parallel	23 to 55 °C	10 <sup>-4</sup> /K	ISO 11359-1,-2	0.75	0.9	0.72	0.85		0.7
<b>C</b> Coefficient of linear thermal expansion, normal	23 to 55 °C	10 <sup>-4</sup> /K	ISO 11359-1,-2	0.8	0.95	0.72	0.85		0.7
<b>C</b> Burning behavior UL 94 (wall thickness)		Class	UL 94	HB (0.85 mm)	HB <sup>2)</sup> (0.85 mm)	HB <sup>2)</sup> (0.85 mm)	HB (0.9 mm)		HB (0.85 mm)
<b>C</b> Burning behavior UL 94 (wall thickness)		Class	UL 94					HB <sup>2)</sup> (1.5 mm)	
<b>C</b> Burning behavior UL 94-5V (wall thickness)		Class	UL 94						
Burning behavior UL 94-5V (wall thickness)		Class	UL 94						
<b>Electrical properties (23 °C / 50 % r. h.)</b>									
<b>C</b> Relative permittivity	100 Hz	–	IEC 60250	3.1	3.0	2,9	3.1		3.1
<b>C</b> Relative permittivity	1 MHz	–	IEC 60250	3.0	2.9	2,8	3.0		2.8
<b>C</b> Dissipation factor	100 Hz	10 <sup>-4</sup>	IEC 60250	20	25	30	20		25
<b>C</b> Dissipation factor	1 MHz	10 <sup>-4</sup>	IEC 60250	85	85	90	100		105
<b>C</b> Volume resistivity		Ohm·m	IEC 60093	1E14	1E14	1E14	1E14		1E14
<b>C</b> Surface resistivity		Ohm	IEC 60093	1E16	1E16	1E17	1E17		1E16
<b>C</b> Electrical strength	1 mm	kV/mm	IEC 60243-1	35	35	45	35		35
<b>C</b> Comparative tracking index (CTI)	Solution A	Rating	IEC 60112	225	275	175	175		225
<b>Other properties (23 °C)</b>									
<b>C</b> Water absorption (saturation value)	Water at 23 °C	%	ISO 62	0.7	0.7	0.7	0.7	0.7	0.5
<b>C</b> Water absorption (equilibrium value)	23 °C; 50 % r. h.	%	ISO 62	0.2	0.2	0.2	0.2	0.2	0.2
<b>C</b> Density	–	kg/m <sup>3</sup>	ISO 1183	1140	1110	1140	1140		1160
Glass fiber content	Method A	%	ISO 3451-1						
<b>Processing conditions for test specimens</b>									
<b>C</b> Injection molding: melt temperature	–	°C	ISO 294	260	260	260	260	260	260
<b>C</b> Injection molding: mold temperature	–	°C	ISO 294	80	80	80	80	80	80
<b>C</b> Injection molding: injection velocity	–	mm/s	ISO 294	240	240	240	240	240	240

**C** These property characteristics are taken from the CAMPUS® plastics data bank and are based on the international catalogue of basic data for plastics according to ISO 10350 (Plastics Acquisition and Presentation of Corporate Single-Point Data, 1993).

Impact properties:  
N = non break  
b. o. = based on  
r. h. = relative humidity

<sup>1)</sup>Determination of true viscosity using the method of representative viscosity

<sup>2)</sup>Bayer test

# Bayblend® – typical values

				Standard grades		
				Glass fiber-reinforced		
Properties	Test conditions	Units	Standards	T88 GF-10	T88 GF-20	T88 GF-30
<b>Rheological properties</b>						
Melt viscosity <sup>1)</sup>	260 °C; 1000 s <sup>-1</sup>	Pas	b. o. ISO 11443-A	205	210	250
<b>C</b> Melt volume-flow rate (MVR)	240 °C; 5 kg	cm <sup>3</sup> /10 min	ISO 1133			
<b>C</b> Melt volume-flow rate (MVR)	260 °C; 5 kg	cm <sup>3</sup> /10 min	ISO 1133			
Molding shrinkage, parallel	150 x 105 x 3 mm; 240 °C / mold 80 °C	%	b. o. ISO 2577			
Molding shrinkage, parallel	150 x 105 x 3 mm; 260 °C / mold 80 °C	%	b. o. ISO 2577	0.25 – 0.45	0.2 – 0.4	0.15 – 0.35
Molding shrinkage, normal	150 x 105 x 3 mm; 240 °C / mold 80 °C	%	b. o. ISO 2577			
Molding shrinkage, normal	150 x 105 x 3 mm; 260 °C / mold 80 °C	%	b. o. ISO 2577	0.35 – 0.55	0.3 – 0.5	0.3 – 0.5
<b>Mechanical properties (23 °C / 50 % r. h.)</b>						
<b>C</b> Tensile modulus	1 mm/min	MPa	ISO 527-1,-2	5100	7500	10000
<b>C</b> Tensile yield stress	50 mm/min	MPa	ISO 527-1,-2			
<b>C</b> Tensile yield strain	50 mm/min	%	ISO 527-1,-2			
Tensile stress at break	50 mm/min	MPa	ISO 527-1,-2			
Tensile strain at break	50 mm/min	%	b. o. ISO 527-1,-2			
Tensile yield stress	5 mm/min	MPa	ISO 527-1,-2	100	120	
Tensile yield strain	5 mm/min	%	ISO 527-1,-2	3.2	2	
<b>C</b> Tensile stress at break	5 mm/min	MPa	ISO 527-1,-2	95	120	135
<b>C</b> Tensile strain at break	5 mm/min	%	ISO 527-1,-2	3.7	2	2
Izod impact strength	23 °C	kJ/m <sup>2</sup>	ISO 180/U	35	38	40
Izod impact strength	-30 °C	kJ/m <sup>2</sup>	ISO 180/U	35	38	40
Izod notched impact strength	23 °C	kJ/m <sup>2</sup>	ISO 180/A	8	8	12
Izod notched impact strength	-20 °C	kJ/m <sup>2</sup>	ISO 180/A			
Izod notched impact strength	-30 °C	kJ/m <sup>2</sup>	ISO 180/A	6	8	11
<b>Thermal properties</b>						
<b>C</b> Temperature of deflection under load	1,80 MPa	°C	ISO 75-1,-2	121	119	126
<b>C</b> Temperature of deflection under load	0,45 MPa	°C	ISO 75-1,-2	134	129	134
<b>C</b> Vicat softening temperature	50 N; 50 °C/h	°C	ISO 306	132	128	132
Vicat softening temperature	50 N; 120 °C/h	°C	ISO 306	134	130	134
<b>C</b> Coefficient of linear thermal expansion, parallel	23 to 55 °C	10 <sup>-4</sup> /K	ISO 11359-1,-2	0.38	0.3	0.25
<b>C</b> Coefficient of linear thermal expansion, normal	23 to 55 °C	10 <sup>-4</sup> /K	ISO 11359-1,-2	0.62	0.7	0.6
<b>C</b> Burning behavior UL 94 (wall thickness)		Class	UL 94	HB (0.85 mm)	HB (0.85 mm)	HB <sup>2)</sup> (0.85 mm)
<b>C</b> Burning behavior UL 94 (wall thickness)		Class	UL 94			
<b>C</b> Burning behavior UL 94-5V (wall thickness)		Class	UL 94			
Burning behavior UL 94-5V (wall thickness)		Class	UL 94			
<b>Electrical properties (23 °C / 50 % r. h.)</b>						
<b>C</b> Relative permittivity	100 Hz	–	IEC 60250	3.2	3.4	3.6
<b>C</b> Relative permittivity	1 MHz	–	IEC 60250	2.9	3.2	3.4
<b>C</b> Dissipation factor	100 Hz	10 <sup>-4</sup>	IEC 60250	25	25	30
<b>C</b> Dissipation factor	1 MHz	10 <sup>-4</sup>	IEC 60250	95	85	85
<b>C</b> Volume resistivity		Ohm·m	IEC 60093	1E14	1E14	1E14
<b>C</b> Surface resistivity		Ohm	IEC 60093	1E16	1E16	1E17
<b>C</b> Electrical strength	1 mm	kV/mm	IEC 60243-1	35	35	35
<b>C</b> Comparative tracking index (CTI)	Solution A	Rating	IEC 60112	200	150	175
<b>Other properties (23 °C)</b>						
<b>C</b> Water absorption (saturation value)	Water at 23 °C	%	ISO 62	0.6	0.6	0.4
<b>C</b> Water absorption (equilibrium value)	23 °C; 50 % r. h.	%	ISO 62	0.2	0.2	0.1
<b>C</b> Density	–	kg/m <sup>3</sup>	ISO 1183	1230	1290	1375
Glass fiber content	Method A	%	ISO 3451-1	10	20	31
<b>Processing conditions for test specimens</b>						
<b>C</b> Injection molding: melt temperature	–	°C	ISO 294	260	260	260
<b>C</b> Injection molding: mold temperature	–	°C	ISO 294	80	80	80
<b>C</b> Injection molding: injection velocity	–	mm/s	ISO 294	540	540	540

**C** These property characteristics are taken from the CAMPUS® plastics data bank and are based on the international catalogue of basic data for plastics according to ISO 10350 (Plastics Acquisition and Presentation of Corporate Single-Point Data, 1993).

Impact properties:  
N = non break  
b. o. = based on  
r. h. = relative humidity

<sup>1)</sup>Determination of true viscosity using the method of representative viscosity  
<sup>2)</sup>Bayer test



# Bayblend® – typical values

				Standard grades		
				Mineral-filled		
Properties	Test conditions	Units	Standards	T95 MF	T90 MF-20	ET 1100
<b>Rheological properties</b>						
Melt viscosity <sup>1)</sup>	260 °C; 1000 s <sup>-1</sup>	Pas	b. o. ISO 11443-A	400	230	600
<b>C</b> Melt volume-flow rate (MVR)	240 °C; 5 kg	cm <sup>3</sup> /10 min	ISO 1133			
<b>C</b> Melt volume-flow rate (MVR)	260 °C; 5 kg	cm <sup>3</sup> /10 min	ISO 1133	18	12	10
Molding shrinkage, parallel	150 x 105 x 3 mm; 240 °C / mold 80 °C	%	b. o. ISO 2577			
Molding shrinkage, parallel	150 x 105 x 3 mm; 260 °C / mold 80 °C	%	b. o. ISO 2577	0.5 – 0.7	0.3 – 0.5	0.5 – 0.7
Molding shrinkage, normal	150 x 105 x 3 mm; 240 °C / mold 80 °C	%	b. o. ISO 2577			
Molding shrinkage, normal	150 x 105 x 3 mm; 260 °C / mold 80 °C	%	b. o. ISO 2577	0.5 – 0.7	0.25 – 0.45	0.5 – 0.7
<b>Mechanical properties (23 °C / 50 % r. h.)</b>						
<b>C</b> Tensile modulus	1 mm/min	MPa	ISO 527-1,-2	3350	5200	3300
<b>C</b> Tensile yield stress	50 mm/min	MPa	ISO 527-1,-2	66	67	60
<b>C</b> Tensile yield strain	50 mm/min	%	ISO 527-1,-2	4.6	3	4.3
Tensile stress at break	50 mm/min	MPa	ISO 527-1,-2	52	66	58
Tensile strain at break	50 mm/min	%	b. o. ISO 527-1,-2	>= 50	3	> 50
Tensile yield stress	5 mm/min	MPa	ISO 527-1,-2			
Tensile yield strain	5 mm/min	%	ISO 527-1,-2			
<b>C</b> Tensile stress at break	5 mm/min	MPa	ISO 527-1,-2			
<b>C</b> Tensile strain at break	5 mm/min	%	ISO 527-1,-2			
Izod impact strength	23 °C	kJ/m <sup>2</sup>	ISO 180/U	>= 150	33	N
Izod impact strength	-30 °C	kJ/m <sup>2</sup>	ISO 180/U		30	N
Izod notched impact strength	23 °C	kJ/m <sup>2</sup>	ISO 180/A	9	6	45
Izod notched impact strength	-20 °C	kJ/m <sup>2</sup>	ISO 180/A			
Izod notched impact strength	-30 °C	kJ/m <sup>2</sup>	ISO 180/A	9	5	13
<b>Thermal properties</b>						
<b>C</b> Temperature of deflection under load	1,80 MPa	°C	ISO 75-1,-2	124	111	125
<b>C</b> Temperature of deflection under load	0,45 MPa	°C	ISO 75-1,-2	136	127	135
<b>C</b> Vicat softening temperature	50 N; 50 °C/h	°C	ISO 306	140	128	140
Vicat softening temperature	50 N; 120 °C/h	°C	ISO 306	142	130	142
<b>C</b> Coefficient of linear thermal expansion, parallel	23 to 55 °C	10 <sup>-4</sup> /K	ISO 11359-1,-2	0.55	0.4	0.55
<b>C</b> Coefficient of linear thermal expansion, normal	23 to 55 °C	10 <sup>-4</sup> /K	ISO 11359-1,-2	0.65	0.56	0.7
<b>C</b> Burning behavior UL 94 (wall thickness)		Class	UL 94	HB (0.85 mm)	HB (0.85 mm)	HB (0.85 mm)
<b>C</b> Burning behavior UL 94 (wall thickness)		Class	UL 94			
<b>C</b> Burning behavior UL 94-5V (wall thickness)		Class	UL 94			
Burning behavior UL 94-5V (wall thickness)		Class	UL 94			
<b>Electrical properties (23 °C / 50 % r. h.)</b>						
<b>C</b> Relative permittivity	100 Hz	–	IEC 60250	3.2	3.3	
<b>C</b> Relative permittivity	1 MHz	–	IEC 60250	3.0	3.2	
<b>C</b> Dissipation factor	100 Hz	10 <sup>-4</sup>	IEC 60250	15	15	
<b>C</b> Dissipation factor	1 MHz	10 <sup>-4</sup>	IEC 60250	90	32	
<b>C</b> Volume resistivity		Ohm·m	IEC 60093	1E14	1E14	
<b>C</b> Surface resistivity		Ohm	IEC 60093	1E16	1E16	
<b>C</b> Electrical strength	1 mm	kV/mm	IEC 60243-1	35	35	35
<b>C</b> Comparative tracking index (CTI)	Solution A	Rating	IEC 60112	200	225	
<b>Other properties (23 °C)</b>						
<b>C</b> Water absorption (saturation value)	Water at 23 °C	%	ISO 62	0.6	0.5	0.6
<b>C</b> Water absorption (equilibrium value)	23 °C; 50 % r. h.	%	ISO 62	0.2	0.2	0.2
<b>C</b> Density	–	kg/m <sup>3</sup>	ISO 1183	1240	1290	1247
Glass fiber content	Method A	%	ISO 3451-1			
<b>Processing conditions for test specimens</b>						
<b>C</b> Injection molding: melt temperature	–	°C	ISO 294	260	260	260
<b>C</b> Injection molding: mold temperature	–	°C	ISO 294	80	80	80
<b>C</b> Injection molding: injection velocity	–	mm/s	ISO 294	240	240	240

**C** These property characteristics are taken from the CAMPUS® plastics data bank and are based on the international catalogue of basic data for plastics according to ISO 10350 (Plastics Acquisition and Presentation of Corporate Single-Point Data, 1993).

Impact properties:  
N = non break  
b. o. = based on  
r. h. = relative humidity

<sup>1)</sup>Determination of true viscosity using the method of representative viscosity

<sup>2)</sup>Bayer test

# Bayblend® – typical values

				FR-grades				
				Non reinforced				
Properties	Test conditions	Units	Standards	FR 3000	FR 3000 HI	FR 3002	FR 3005	FR 3005 HF
<b>Rheological properties</b>								
Melt viscosity <sup>1)</sup>	260 °C; 1000 s <sup>-1</sup>	Pas	b. o. ISO 11443-A	160	185	190	125	105
<b>C</b> Melt volume-flow rate (MVR)	240 °C; 5 kg	cm <sup>3</sup> /10 min	ISO 1133	24	20	19	30	40
<b>C</b> Melt volume-flow rate (MVR)	260 °C; 5 kg	cm <sup>3</sup> /10 min	ISO 1133					
Molding shrinkage, parallel	150 x 105 x 3 mm; 240 °C / mold 80 °C	%	b. o. ISO 2577	0.5 – 0.7	0.5 – 0.7	0.5 – 0.7	0.5 – 0.7	0.5 – 0.7
Molding shrinkage, parallel	150 x 105 x 3 mm; 260 °C / mold 80 °C	%	b. o. ISO 2577					
Molding shrinkage, normal	150 x 105 x 3 mm; 240 °C / mold 80 °C	%	b. o. ISO 2577	0.5 – 0.7	0.5 – 0.7	0.5 – 0.7	0.5 – 0.7	0.5 – 0.7
Molding shrinkage, normal	150 x 105 x 3 mm; 260 °C / mold 80 °C	%	b. o. ISO 2577					
<b>Mechanical properties (23 °C / 50 % r. h.)</b>								
<b>C</b> Tensile modulus	1 mm/min	MPa	ISO 527-1,-2	2700	2700	2700	2800	2700
<b>C</b> Tensile yield stress	50 mm/min	MPa	ISO 527-1,-2	60	60	60	60	60
<b>C</b> Tensile yield strain	50 mm/min	%	ISO 527-1,-2	3.5	4.0	4.0	3.5	3.5
Tensile stress at break	50 mm/min	MPa	ISO 527-1,-2	45	45	50	45	45
Tensile strain at break	50 mm/min	%	b. o. ISO 527-1,-2	> 40	> 50	> 50	> 30	> 40
Tensile yield stress	5 mm/min	MPa	ISO 527-1,-2					
Tensile yield strain	5 mm/min	%	ISO 527-1,-2					
<b>C</b> Tensile stress at break	5 mm/min	MPa	ISO 527-1,-2					
<b>C</b> Tensile strain at break	5 mm/min	%	ISO 527-1,-2					
Izod impact strength	23 °C	kJ/m <sup>2</sup>	ISO 180/U	N	N	N	N	N
Izod impact strength	-30 °C	kJ/m <sup>2</sup>	ISO 180/U					
Izod notched impact strength	23 °C	kJ/m <sup>2</sup>	ISO 180/A	35	35	30	18	13
Izod notched impact strength	-20 °C	kJ/m <sup>2</sup>	ISO 180/A					
Izod notched impact strength	-30 °C	kJ/m <sup>2</sup>	ISO 180/A	10	10		8	8
<b>Thermal properties</b>								
<b>C</b> Temperature of deflection under load	1,80 MPa	°C	ISO 75-1,-2	82	82	84	78	81
<b>C</b> Temperature of deflection under load	0,45 MPa	°C	ISO 75-1,-2	92	92	92	87	90
<b>C</b> Vicat softening temperature	50 N; 50 °C/h	°C	ISO 306	95	95	97	93	94
Vicat softening temperature	50 N; 120 °C/h	°C	ISO 306	97	97	99	95	96
<b>C</b> Coefficient of linear thermal expansion, parallel	23 to 55 °C	10 <sup>-4</sup> /K	ISO 11359-1,-2	0.76	0.76	0.76	0.76	0.76
<b>C</b> Coefficient of linear thermal expansion, normal	23 to 55 °C	10 <sup>-4</sup> /K	ISO 11359-1,-2	0.8	0.8	0.8	0.8	0.8
<b>C</b> Burning behavior UL 94 (wall thickness)		Class	UL 94					
<b>C</b> Burning behavior UL 94 (wall thickness)		Class	UL 94	V-0 (1.5 mm)	V-0 (1.5 mm)	V-0 (1.2 mm)	V-0 (1.5 mm)	V-0 (1.5 mm)
<b>C</b> Burning behavior UL 94-5V (wall thickness)		Class	UL 94	5VB (2 mm)	5VB (2 mm)	5VB <sup>2)</sup> (2 mm)	5VB (2 mm)	5VB (2 mm)
Burning behavior UL 94-5V (wall thickness)		Class	UL 94	5VA (3 mm)	5VA (3 mm)		5VA (3 mm)	5VA (3 mm)
<b>Electrical properties (23 °C / 50 % r. h.)</b>								
<b>C</b> Relative permittivity	100 Hz	–	IEC 60250	3.2	3.2	3.2	3.2	3.2
<b>C</b> Relative permittivity	1 MHz	–	IEC 60250	3.1	3.1	3.1	3.1	3.1
<b>C</b> Dissipation factor	100 Hz	10 <sup>-4</sup>	IEC 60250	50	50	50	50	50
<b>C</b> Dissipation factor	1 MHz	10 <sup>-4</sup>	IEC 60250	60	60	60	65	65
<b>C</b> Volume resistivity		Ohm·m	IEC 60093	1E14	1E14	1E14	1E14	1E14
<b>C</b> Surface resistivity		Ohm	IEC 60093	1E16	1E16	1E16	1E16	1E16
<b>C</b> Electrical strength	1 mm	kV/mm	IEC 60243-1	35	35	35	35	35
<b>C</b> Comparative tracking index (CTI)	Solution A	Rating	IEC 60112	350	350	350	350	350
<b>Other properties (23 °C)</b>								
<b>C</b> Water absorption (saturation value)	Water at 23 °C	%	ISO 62	0.5	0.5	0.5	0.5	0.5
<b>C</b> Water absorption (equilibrium value)	23 °C; 50 % r. h.	%	ISO 62	0.2	0.2	0.2	0.2	0.2
<b>C</b> Density	–	kg/m <sup>3</sup>	ISO 1183	1180	1180	1180	1180	1180
Glass fiber content	Method A	%	ISO 3451-1					
<b>Processing conditions for test specimens</b>								
<b>C</b> Injection molding: melt temperature	–	°C	ISO 294	240	240	240	240	240
<b>C</b> Injection molding: mold temperature	–	°C	ISO 294	80	80	80	80	80
<b>C</b> Injection molding: injection velocity	–	mm/s	ISO 294	240	240	240	240	240

**C** These property characteristics are taken from the CAMPUS® plastics data bank and are based on the international catalogue of basic data for plastics according to ISO 10350 (Plastics Acquisition and Presentation of Corporate Single-Point Data, 1993).

Impact properties:  
N = non break  
b. o. = based on  
r. h. = relative humidity

<sup>1)</sup>Determination of true viscosity using the method of representative viscosity  
<sup>2)</sup>Bayer test

				FR-grades					
				Non reinforced					
Properties	Test conditions	Units	Standards	FR 3006	FR 3008	FR 3008 HR	FR 3010	FR 3010 IF	FR 3011
<b>Rheological properties</b>									
Melt viscosity <sup>1)</sup>	260 °C; 1000 s <sup>-1</sup>	Pas	b. o. ISO 11443-A	140	195	195	245	210	240
<b>C</b> Melt volume-flow rate (MVR)	240 °C; 5 kg	cm <sup>3</sup> /10 min	ISO 1133	32	13	13	15	17	17
<b>C</b> Melt volume-flow rate (MVR)	260 °C; 5 kg	cm <sup>3</sup> /10 min	ISO 1133						
Molding shrinkage, parallel	150 x 105 x 3 mm; 240 °C / mold 80 °C	%	b. o. ISO 2577	0.5 – 0.7	0.5 – 0.7	0.5 – 0.7	0.5 – 0.7	0.5 – 0.7	0.5 – 0.7
Molding shrinkage, parallel	150 x 105 x 3 mm; 260 °C / mold 80 °C	%	b. o. ISO 2577						
Molding shrinkage, normal	150 x 105 x 3 mm; 240 °C / mold 80 °C	%	b. o. ISO 2577	0.5 – 0.7	0.5 – 0.7	0.5 – 0.7	0.5 – 0.7	0.5 – 0.7	0.5 – 0.7
Molding shrinkage, normal	150 x 105 x 3 mm; 260 °C / mold 80 °C	%	b. o. ISO 2577						
<b>Mechanical properties (23 °C / 50 % r. h.)</b>									
<b>C</b> Tensile modulus	1 mm/min	MPa	ISO 527-1,-2	2700	2800	2800	2700	2700	2600
<b>C</b> Tensile yield stress	50 mm/min	MPa	ISO 527-1,-2	60	60	60	60	60	65
<b>C</b> Tensile yield strain	50 mm/min	%	ISO 527-1,-2	4	4	4	4	4	4
Tensile stress at break	50 mm/min	MPa	ISO 527-1,-2	50	50	50	50	50	50
Tensile strain at break	50 mm/min	%	b. o. ISO 527-1,-2	> 50	> 50	> 50	> 50	> 50	> 50
Tensile yield stress	5 mm/min	MPa	ISO 527-1,-2						
Tensile yield strain	5 mm/min	%	ISO 527-1,-2						
<b>C</b> Tensile stress at break	5 mm/min	MPa	ISO 527-1,-2						
<b>C</b> Tensile strain at break	5 mm/min	%	ISO 527-1,-2						
Izod impact strength	23 °C	kJ/m <sup>2</sup>	ISO 180/U	N	N	N	N	N	N
Izod impact strength	-30 °C	kJ/m <sup>2</sup>	ISO 180/U						
Izod notched impact strength	23 °C	kJ/m <sup>2</sup>	ISO 180/A	12	30	30	35	25	12
Izod notched impact strength	-20 °C	kJ/m <sup>2</sup>	ISO 180/A						
Izod notched impact strength	-30 °C	kJ/m <sup>2</sup>	ISO 180/A		10	10	10		10
<b>Thermal properties</b>									
<b>C</b> Temperature of deflection under load	1,80 MPa	°C	ISO 75-1,-2	91	85	85	90	88	98
<b>C</b> Temperature of deflection under load	0,45 MPa	°C	ISO 75-1,-2	101	95	95	100	98	108
<b>C</b> Vicat softening temperature	50 N; 50 °C/h	°C	ISO 306	108	101	101	108	106	116
Vicat softening temperature	50 N; 120 °C/h	°C	ISO 306	110	103	103	110	108	118
<b>C</b> Coefficient of linear thermal expansion, parallel	23 to 55 °C	10 <sup>-4</sup> /K	ISO 11359-1,-2	0.68	0.76	0.76	0.76	0.76	0.7
<b>C</b> Coefficient of linear thermal expansion, normal	23 to 55 °C	10 <sup>-4</sup> /K	ISO 11359-1,-2	0.68	0.8	0.8	0.8	0.8	0.7
<b>C</b> Burning behavior UL 94 (wall thickness)		Class	UL 94	V-1 (1.5mm)					
<b>C</b> Burning behavior UL 94 (wall thickness)		Class	UL 94	V-0 (2mm)	V-0 (1.5 mm)	V-0 (1.5 mm)	V-0 (1.5 mm)	V-0 (1.5 mm)	V-0 (1.5 mm)
<b>C</b> Burning behavior UL 94-5V (wall thickness)		Class	UL 94		5VB (2 mm)	5VB (2 mm)	5VB (2 mm)	5VB (1.5 mm)	5VB (2 mm)
Burning behavior UL 94-5V (wall thickness)		Class	UL 94		5VA (3 mm)		5VA (3 mm)	5VA (3 mm)	5VA (3 mm)
<b>Electrical properties (23 °C / 50 % r. h.)</b>									
<b>C</b> Relative permittivity	100 Hz	–	IEC 60250	3.2	3.2	3.2	3.2		3.2
<b>C</b> Relative permittivity	1 MHz	–	IEC 60250	3.1	3.1	3.1	3.1		3.1
<b>C</b> Dissipation factor	100 Hz	10 <sup>-4</sup>	IEC 60250	50	50	50	50		40
<b>C</b> Dissipation factor	1 MHz	10 <sup>-4</sup>	IEC 60250	70	70	70	70		75
<b>C</b> Volume resistivity		Ohm·m	IEC 60093	1E14	1E14	1E14	1E14		1E15
<b>C</b> Surface resistivity		Ohm	IEC 60093	1E16	1E16	1E16	1E16		1E17
<b>C</b> Electrical strength	1 mm	kV/mm	IEC 60243-1	30	30	30	35		35
<b>C</b> Comparative tracking index (CTI)	Solution A	Rating	IEC 60112	350	300	300	350		250
<b>Other properties (23 °C)</b>									
<b>C</b> Water absorption (saturation value)	Water at 23 °C	%	ISO 62	0.5	0.5	0.5	0.5	0.5	0.5
<b>C</b> Water absorption (equilibrium value)	23 °C; 50 % r. h.	%	ISO 62	0.2	0.2	0.2	0.2	0.2	0.2
<b>C</b> Density	–	kg/m <sup>3</sup>	ISO 1183	1180	1180	1180	1180	1180	1190
Glass fiber content	Method A	%	ISO 3451-1						
<b>Processing conditions for test specimens</b>									
<b>C</b> Injection molding: melt temperature	–	°C	ISO 294	240	240	240	240	240	240
<b>C</b> Injection molding: mold temperature	–	°C	ISO 294	80	80	80	80	80	80
<b>C</b> Injection molding: injection velocity	–	mm/s	ISO 294	240	240	240	240	240	240

**C** These property characteristics are taken from the CAMPUS® plastics data bank and are based on the international catalogue of basic data for plastics according to ISO 10350 (Plastics Acquisition and Presentation of Corporate Single-Point Data, 1993).

Impact properties:  
N = non break  
b. o. = based on  
r. h. = relative humidity

<sup>1)</sup>Determination of true viscosity using the method of representative viscosity

<sup>2)</sup>Bayer test

# Bayblend® – typical values

				FR-grades				
				Non reinforced				
Properties	Test conditions	Units	Standards	FR 3030	FR 3100 TV	FR 3110 TV	KU 2-1514	KU 2-1514 BBS073
<b>Rheological properties</b>								
Melt viscosity <sup>1)</sup>	260 °C; 1000 s <sup>-1</sup>	Pas	b. o. ISO 11443-A	410	160	140	450	520
<b>C</b> Melt volume-flow rate (MVR)	240 °C; 5 kg	cm <sup>3</sup> /10 min	ISO 1133		22	32		
<b>C</b> Melt volume-flow rate (MVR)	260 °C; 5 kg	cm <sup>3</sup> /10 min	ISO 1133	10			19	15
Molding shrinkage, parallel	150 x 105 x 3 mm; 240 °C / mold 80 °C	%	b. o. ISO 2577		0.5 – 0.7	0.5 – 0.7		
Molding shrinkage, parallel	150 x 105 x 3 mm; 260 °C / mold 80 °C	%	b. o. ISO 2577	0.5 – 0.7			0.5 – 0.7	0.5 – 0.7
Molding shrinkage, normal	150 x 105 x 3 mm; 240 °C / mold 80 °C	%	b. o. ISO 2577		0.5 – 0.7	0.5 – 0.7		
Molding shrinkage, normal	150 x 105 x 3 mm; 260 °C / mold 80 °C	%	b. o. ISO 2577	0.5 – 0.7			0.5 – 0.7	0.5 – 0.7
<b>Mechanical properties (23 °C / 50 % r. h.)</b>								
<b>C</b> Tensile modulus	1 mm/min	MPa	ISO 527-1,-2	2700	2700	2700	2400	2400
<b>C</b> Tensile yield stress	50 mm/min	MPa	ISO 527-1,-2	69	60	60	60	57
<b>C</b> Tensile yield strain	50 mm/min	%	ISO 527-1,-2	5	4	4	5	5
Tensile stress at break	50 mm/min	MPa	ISO 527-1,-2	53	50	50	54	50
Tensile strain at break	50 mm/min	%	b. o. ISO 527-1,-2	> 50	> 50	> 50	> 50	> 50
Tensile yield stress	5 mm/min	MPa	ISO 527-1,-2					
Tensile yield strain	5 mm/min	%	ISO 527-1,-2					
<b>C</b> Tensile stress at break	5 mm/min	MPa	ISO 527-1,-2					
<b>C</b> Tensile strain at break	5 mm/min	%	ISO 527-1,-2					
Izod impact strength	23 °C	kJ/m <sup>2</sup>	ISO 180/U	N	N	N	N	N
Izod impact strength	-30 °C	kJ/m <sup>2</sup>	ISO 180/U					
Izod notched impact strength	23 °C	kJ/m <sup>2</sup>	ISO 180/A	40	25	12	45	55
Izod notched impact strength	-20 °C	kJ/m <sup>2</sup>	ISO 180/A					
Izod notched impact strength	-30 °C	kJ/m <sup>2</sup>	ISO 180/A	10			15	15
<b>Thermal properties</b>								
<b>C</b> Temperature of deflection under load	1,80 MPa	°C	ISO 75-1,-2	96	91	91	115	115
<b>C</b> Temperature of deflection under load	0,45 MPa	°C	ISO 75-1,-2	106	101	101	126	126
<b>C</b> Vicat softening temperature	50 N; 50 °C/h	°C	ISO 306	113	108	108	134	134
Vicat softening temperature	50 N; 120 °C/h	°C	ISO 306	115	110	110	136	136
<b>C</b> Coefficient of linear thermal expansion, parallel	23 to 55 °C	10 <sup>-4</sup> /K	ISO 11359-1,-2	0.76	0.73	0.68	0.68	0.68
<b>C</b> Coefficient of linear thermal expansion, normal	23 to 55 °C	10 <sup>-4</sup> /K	ISO 11359-1,-2	0.8	0.75	0.68	0.68	0.68
<b>C</b> Burning behavior UL 94 (wall thickness)		Class	UL 94		V-1 (1.5mm)	V-1 <sup>2)</sup> (1.5mm)		
<b>C</b> Burning behavior UL 94 (wall thickness)		Class	UL 94	V-0 (1.5 mm)	V-0 (2mm)	V-0 <sup>2)</sup> (2mm)	V-0 (1.5 mm)	V-0 (1.5 mm)
<b>C</b> Burning behavior UL 94-5V (wall thickness)		Class	UL 94	5VB (2 mm)			5VB (2 mm)	5VB (2 mm)
Burning behavior UL 94-5V (wall thickness)		Class	UL 94	5VA (3 mm)			5VA (3 mm)	5VA (3 mm)
<b>Electrical properties (23 °C / 50 % r. h.)</b>								
<b>C</b> Relative permittivity	100 Hz	–	IEC 60250	3.2	3.2	3.2	3.2	3.2
<b>C</b> Relative permittivity	1 MHz	–	IEC 60250	3.1	3.1	3.1	3.1	3.1
<b>C</b> Dissipation factor	100 Hz	10 <sup>-4</sup>	IEC 60250	37	50	50	20	20
<b>C</b> Dissipation factor	1 MHz	10 <sup>-4</sup>	IEC 60250	75	70	70	80	80
<b>C</b> Volume resistivity		Ohm·m	IEC 60093	1E15	1E14	1E14	1E15	1E15
<b>C</b> Surface resistivity		Ohm	IEC 60093	1E17	1E16	1E16	1E17	1E17
<b>C</b> Electrical strength	1 mm	kV/mm	IEC 60243-1	35	30	30	35	35
<b>C</b> Comparative tracking index (CTI)	Solution A	Rating	IEC 60112	350	350	350	350	350
<b>Other properties (23 °C)</b>								
<b>C</b> Water absorption (saturation value)	Water at 23 °C	%	ISO 62	0.5	0.5	0.5	0.5	0.5
<b>C</b> Water absorption (equilibrium value)	23 °C; 50 % r. h.	%	ISO 62	0.2	0.2	0.2	0.2	0.2
<b>C</b> Density	–	kg/m <sup>3</sup>	ISO 1183	1180	1180	1180	1190	1190
Glass fiber content	Method A	%	ISO 3451-1					
<b>Processing conditions for test specimens</b>								
<b>C</b> Injection molding: melt temperature	–	°C	ISO 294	260	240	240	260	260
<b>C</b> Injection molding: mold temperature	–	°C	ISO 294	80	80	80	80	80
<b>C</b> Injection molding: injection velocity	–	mm/s	ISO 294	240	240	240	240	240

**C** These property characteristics are taken from the CAMPUS® plastics data bank and are based on the international catalogue of basic data for plastics according to ISO 10350 (Plastics Acquisition and Presentation of Corporate Single-Point Data, 1993).

Impact properties:  
N = non break  
b. o. = based on  
r. h. = relative humidity

<sup>1)</sup>Determination of true viscosity using the method of representative viscosity  
<sup>2)</sup>Bayer test

				FR-grades			
				Mineral-filled			
Properties	Test conditions	Units	Standards	ET 3032 FR	FR 410 MT	FR 3020	FR 3021
<b>Rheological properties</b>							
Melt viscosity <sup>1)</sup>	260 °C; 1000 s <sup>-1</sup>	Pas	b. o. ISO 11443-A	380	360	200	165
<b>C</b> Melt volume-flow rate (MVR)	240 °C; 5 kg	cm <sup>3</sup> /10 min	ISO 1133			20	13
<b>C</b> Melt volume-flow rate (MVR)	260 °C; 5 kg	cm <sup>3</sup> /10 min	ISO 1133	10	10		
Molding shrinkage, parallel	150 x 105 x 3 mm; 240 °C / mold 80 °C	%	b. o. ISO 2577			0.4 – 0.6	0.3 – 0.5
Molding shrinkage, parallel	150 x 105 x 3 mm; 260 °C / mold 80 °C	%	b. o. ISO 2577	0.4 – 0.5	0.4 – 0.5		
Molding shrinkage, normal	150 x 105 x 3 mm; 240 °C / mold 80 °C	%	b. o. ISO 2577			0.4 – 0.6	0.3 – 0.5
Molding shrinkage, normal	150 x 105 x 3 mm; 260 °C / mold 80 °C	%	b. o. ISO 2577	0.4 – 0.5	0.4 – 0.5		
<b>Mechanical properties (23 °C / 50 % r. h.)</b>							
<b>C</b> Tensile modulus	1 mm/min	MPa	ISO 527-1,-2	3950	3950	3200	4800
<b>C</b> Tensile yield stress	50 mm/min	MPa	ISO 527-1,-2	63	63	65	65
<b>C</b> Tensile yield strain	50 mm/min	%	ISO 527-1,-2	4	4	4	3
Tensile stress at break	50 mm/min	MPa	ISO 527-1,-2	50	50	50	40
Tensile strain at break	50 mm/min	%	b. o. ISO 527-1,-2	15	19	> 30	10
Tensile yield stress	5 mm/min	MPa	ISO 527-1,-2				
Tensile yield strain	5 mm/min	%	ISO 527-1,-2				
<b>C</b> Tensile stress at break	5 mm/min	MPa	ISO 527-1,-2				
<b>C</b> Tensile strain at break	5 mm/min	%	ISO 527-1,-2				
Izod impact strength	23 °C	kJ/m <sup>2</sup>	ISO 180/U				
Izod impact strength	-30 °C	kJ/m <sup>2</sup>	ISO 180/U				
Izod notched impact strength	23 °C	kJ/m <sup>2</sup>	ISO 180/A	9	9	11	6
Izod notched impact strength	-20 °C	kJ/m <sup>2</sup>	ISO 180/A				
Izod notched impact strength	-30 °C	kJ/m <sup>2</sup>	ISO 180/A	7	7		
<b>Thermal properties</b>							
<b>C</b> Temperature of deflection under load	1,80 MPa	°C	ISO 75-1,-2	94	94	85	85
<b>C</b> Temperature of deflection under load	0,45 MPa	°C	ISO 75-1,-2			95	92
<b>C</b> Vicat softening temperature	50 N; 50 °C/h	°C	ISO 306	106	106	101	96
Vicat softening temperature	50 N; 120 °C/h	°C	ISO 306	108	108	103	98
<b>C</b> Coefficient of linear thermal expansion, parallel	23 to 55 °C	10 <sup>-4</sup> /K	ISO 11359-1,-2	0.48	0.48	0.7	0.46
<b>C</b> Coefficient of linear thermal expansion, normal	23 to 55 °C	10 <sup>-4</sup> /K	ISO 11359-1,-2	0.59	0.59	0.7	0.63
<b>C</b> Burning behavior UL 94 (wall thickness)		Class	UL 94	V-0 <sup>2)</sup> (0.75 mm)	V-0 (0.75 mm)	V-0 (0.75 mm)	
<b>C</b> Burning behavior UL 94 (wall thickness)		Class	UL 94				V-0 (1.5 mm)
<b>C</b> Burning behavior UL 94-5V (wall thickness)		Class	UL 94	5VB <sup>2)</sup> (2 mm)	5VB (2 mm)	5VB (2 mm)	
Burning behavior UL 94-5V (wall thickness)		Class	UL 94	5VA <sup>2)</sup> (3 mm)	5VA (3 mm)	5VA (3 mm)	
<b>Electrical properties (23 °C / 50 % r. h.)</b>							
<b>C</b> Relative permittivity	100 Hz	–	IEC 60250			3.1	3.1
<b>C</b> Relative permittivity	1 MHz	–	IEC 60250			3.0	3.0
<b>C</b> Dissipation factor	100 Hz	10 <sup>-4</sup>	IEC 60250			50	50
<b>C</b> Dissipation factor	1 MHz	10 <sup>-4</sup>	IEC 60250			70	70
<b>C</b> Volume resistivity		Ohm·m	IEC 60093			1E14	1E14
<b>C</b> Surface resistivity		Ohm	IEC 60093			1E16	1E16
<b>C</b> Electrical strength	1 mm	kV/mm	IEC 60243-1			35	35
<b>C</b> Comparative tracking index (CTI)	Solution A	Rating	IEC 60112			275	275
<b>Other properties (23 °C)</b>							
<b>C</b> Water absorption (saturation value)	Water at 23 °C	%	ISO 62	0.5	0.5	0.5	0.5
<b>C</b> Water absorption (equilibrium value)	23 °C; 50 % r. h.	%	ISO 62	0.2	0.2	0.2	0.2
<b>C</b> Density	–	kg/m <sup>3</sup>	ISO 1183	1300	1300	1200	1280
Glass fiber content	Method A	%	ISO 3451-1				
<b>Processing conditions for test specimens</b>							
<b>C</b> Injection molding: melt temperature	–	°C	ISO 294	260	260	240	240
<b>C</b> Injection molding: mold temperature	–	°C	ISO 294	80	80	80	80
<b>C</b> Injection molding: injection velocity	–	mm/s	ISO 294	240	240	240	240

**C** These property characteristics are taken from the CAMPUS® plastics data bank and are based on the international catalogue of basic data for plastics according to ISO 10350 (Plastics Acquisition and Presentation of Corporate Single-Point Data, 1993).

Impact properties:  
N = non break  
b. o. = based on  
r. h. = relative humidity

<sup>1)</sup>Determination of true viscosity using the method of representative viscosity

<sup>2)</sup>Bayer test

## PROPERTIES

The outstanding feature of Bayblend® is its balanced combination of high heat resistance, strength and stiffness.

### Mechanical properties

Bayblend® displays a high impact and notched impact strength over a wide temperature range. With increasing polycarbonate content, the energy absorption in the dart penetration test increases. Due to the good low-temperature impact strength for multi axial loads, ductile fracture behavior is reached at -30 °C, particularly with the non-reinforced Bayblend® T grades.

It should be noted that at low temperatures the notched impact strength is higher than with pure ABS and pure polycarbonates. At the so-called critical temperature, Bayblend® exhibits a rapid change in the value of its notched impact strength. In this temperature range, there is a change in the fracture pattern. One advantage is the fact that the ductile to brittle transition of Bayblend® is at a much lower temperature than that of pure polycarbonate. A few characteristic mechanical properties obtained from accelerated tests are listed in the guide value table.

As for all plastic materials, the mechanical properties change not only with temperature, but also with the period of loading. The isochronous stress-strain diagram provides a measure of the stress-strain behavior in relation to the

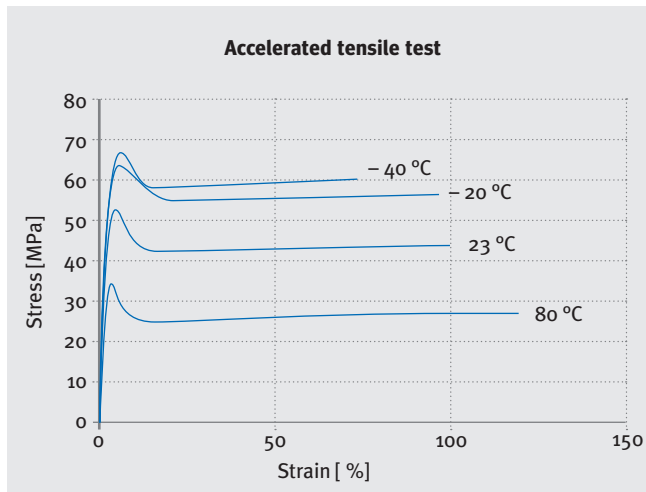
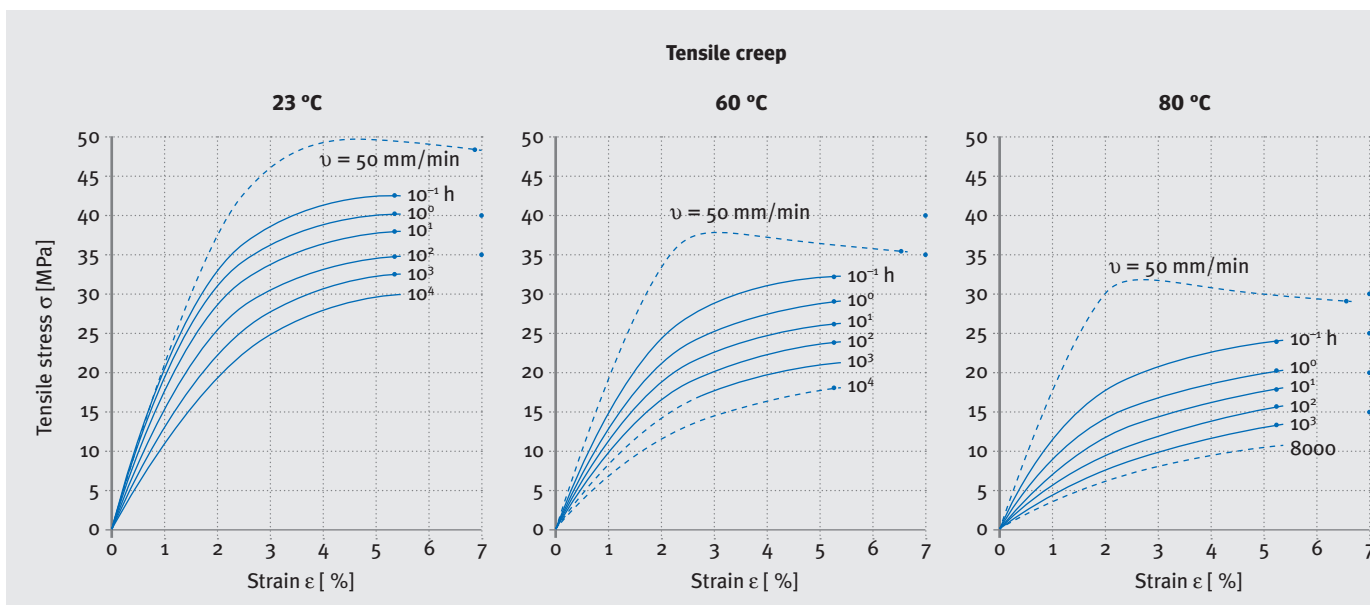

Fig. 1: Temperature-dependent stress-strain diagram for Bayblend T65 according to ISO 527-1,-2

period of loading. The longer the period of loading, the flatter the characteristic curve becomes.

Bayblend® can be reinforced with glass fibers in order to improve stiffness and stability. Grades are available with 10, 20 and 30 % glass fiber content. A 10 % increase in glass fiber content results in an increase of at least 2000 MPa in the tensile modulus.

Furthermore, Bayblend® grades are available with up to 20 % mineral filling, which, in addition to increased stiffness, are distinguished in particular by low, isotropic, lin-



Figs. 2 to 4: Tensile creep according to DIN 53444 at various temperatures. Isochronous stress-strain curves. Bayblend® general-purpose grade Vicat 120 °C

ear thermal coefficients of expansion and molding shrinkage.

For applications with dynamic loading, pilot tests on components are recommended.

The property values illustrated here were determined using ideal test specimens. Due to various influences (e.g. geometry of the molding, processing conditions, contact with media) and depending on the application, appropriate reduction factors must be taken into account and the relevant practical loading must be tested on actual molded parts.

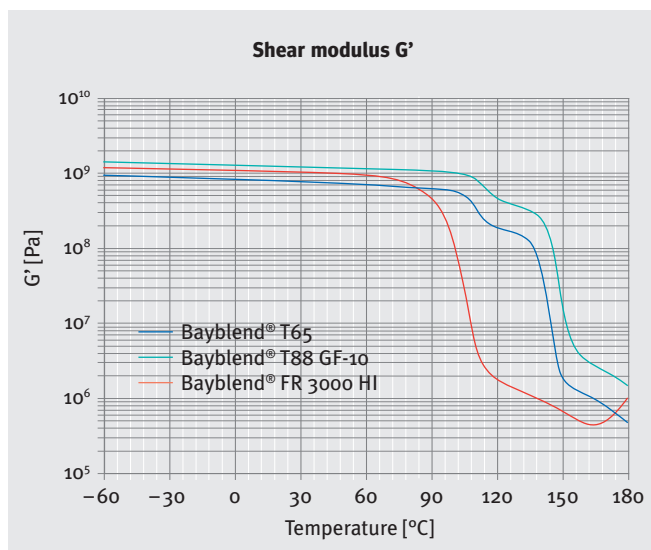

Fig. 5: Shear modulus  $G'$  from Bayblend® T65, T88 GF-10 and FR 3000 HI

### Thermal properties

Depending on the type of application, thermal loading such as solar radiation, engine heat, etc. occurs, which makes high heat resistance a prerequisite. Bayblend® spans practically the whole range of heat resistance between ABS and polycarbonate. Thus the Bayblend® general purpose grades exhibit heat resistance to Vicat B 120 of between 112 and 142 °C, and FR grade products are available between 95 und 136 °C Vicat. In practice, the heat resistance of Bayblend® is higher than that of ABS for the same Vicat temperature, so that, influenced by the molding design, the practical requirements and the processing conditions, the short-term thermal loading can often be higher than the Vicat temperature, without any appreciable dimensional changes to the molding. The reason for this is the residual modulus at temperatures above the Vicat tem-

perature caused by the glass transition temperature of the polycarbonate of approx. 150 °C.

In the electrical sector, the housings must not warp excessively under thermal loading. Normal Bayblend® grades have a heat resistance range between 85 and 125 °C (ball indentation temperature (IEC 60335)). This makes them suitable for use as insulating housings. A few high heat resistance grades even reach values  $\geq 125$  °C and can therefore be used with live components.

The linear thermal coefficient of expansion is in the range of ABS and is somewhat higher than that of pure polycarbonate. Nonreinforced and mineral-filled grades exhibit a small dependency on the direction of molding. With glass fiber-reinforced grades, the values are strongly dependent on the orientation of the glass fibers. The mineral-filled grades are distinguished by a considerably reduced linear thermal coefficient of expansion and by their anisotropy.

### Electrical properties

The most crucial requirements for live parts are protection against contact and safe and permanent insulation. With a specific volume resistance  $> 10^{16} \Omega$ , Bayblend® fulfills the insulation resistance requirements in the low-voltage range up to 4000 V, as proved by practical tests on actual molded parts.

The surface resistivity is greater than  $10^{14} \Omega$ . Due to the very low water absorption, the dependence of this value on ambient humidity is negligible.

A creep resistance of at least 175 V (according to CTI) is demanded for housing components in the electrical, electronic and IT industries. As a rule Bayblend® grades comfortably exceed this value.

For applications in the electrical sector, the relative permittivity of the material used should be as independent of the frequency and temperature ranges as possible. Bayblend® exhibits largely constant values across a wide range of temperatures and frequencies.

### Rheological properties

The flowability of Bayblend® grades is dependent on the proportion of polycarbonate and its molecular weight and the type and content of rubber. Flowability and heat resistance are generally inversely proportional. Filling and

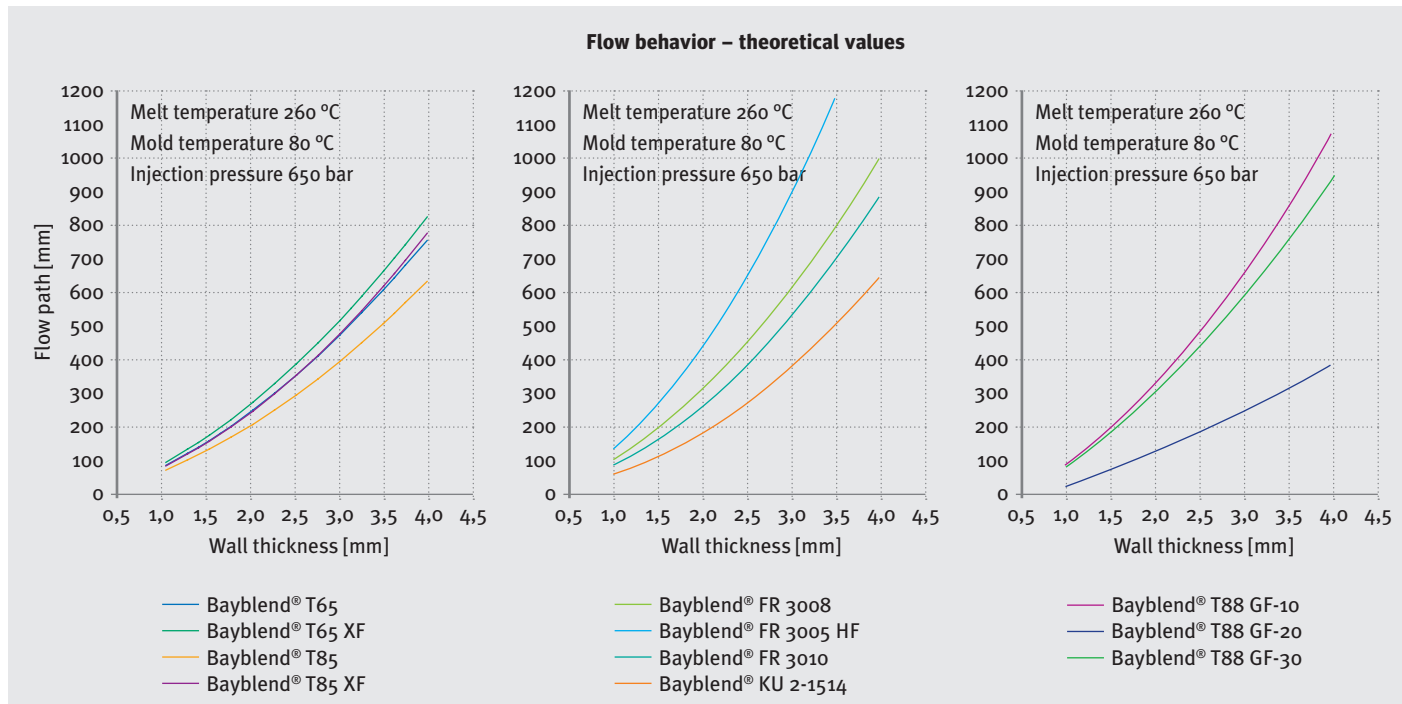

**Figs. 6 to 8: Flow path/wall thickness diagrams**

**Bayblend® general purpose grades: T65, T65 XF, T85 and T85 XF**

**Bayblend® FR grades: FR 3008, FR 3005 HF, FR 3010 and KU 2-1514**

**Bayblend® GF grades: T88 GF-10, T88 GF-20 and T88 GF-30**

reinforcing materials generally lead to a reduction in flowability. However, as a result of product optimization, there are filled/reinforced Bayblend® grades available with excellent flow properties, which are even suitable for thin-wall applications.

Figs. 6 to 8 illustrate the flow path/wall thickness diagrams for a few general purpose, GF and FR grades. The calculation was based on a maximum injection pressure in the mold of 650 bar, and a typical melt temperature (260 °C). From the diagrams it can be seen that with Bayblend® even complicated, thin-wall moldings with long flow paths can be realized without difficulty by suitable gate and tool design.

The Bayblend® grades suitable for extrusion, T65 HI and FR 3030, are distinguished by a particularly high pseudoplasticity. The consequence is that with low shear rates, such as in extrusion or extrusion blow molding, there is a very high melt stability, whereas with higher shear rates, such as in injection molding, the viscosity is comparatively low.

Due to the different, very distinctive pseudoplasticity of the Bayblend® grades, the melt volume flow rate (MVR) cannot be utilized directly for a comparative evaluation

of the flowability of different Bayblend® grades. The MVR measurement takes place in a shear rate zone that has no practical relevance for the injection molding process.

### Burning behavior

The most important flammability classification in the world for the IT, electrical and electronic industries is the UL 94 rating according to Underwriters Laboratories Inc., USA. The qualitatively highest grading is “V-0” and is satisfied by Bayblend® FR for the smallest possible wall thickness (from a minimum of 0.75 mm up to, as a rule, 1.5 mm) depending on grade.

Non-flame-retardant Bayblend® is classified HB according to the UL 94 test standard.

Materials used for vehicle interiors may not exceed a certain burn rate according to US-FMVSS 302. All Bayblend® grades are well below the permitted maximum value of 101.6 mm/min for wall thicknesses from 1 mm.

Furthermore, the Bayblend® FR grades in the wall thickness range of 1.0 to 3.0 mm will usually comply comfortably with the glow wire test IEC 60695-2 according to the requirements of the domestic appliance standards of



IEC 60335-1 for the required 850 °C glow wire flammability index of IEC 60695-2-12 (GWFI) and the required 775 °C glow wire ignitability temperature of IEC 60695-2-13 (GWIT).

### Flame-retardant additives

The flame-retardant system used in the latest Bayblend® FR 3000 generation is based on an advanced combination of oligomer phosphate with PTFE. From a technical, ecological and economic perspective, this enables a future-oriented technology to enter the market for flame-retardant blends (PC+ABS). The flame-retardant package for all Bayblend® FR grades is free of antimony, chlorine and bromine.

The advantages of using a flame-retardant system based on phosphate/PTFE:

- Maximum flame retardance in accordance with UL 94
- The typical range of properties of Bayblend® (PC+ABS) is retained
- The flame-retardant system used is
  - free of chlorine, bromine and heavy metals (antimony),
  - toxicologically harmless.

Bayblend® FR grades fulfill the requirements of materials used in the manufacture of products which are awarded an environmental symbol (ecolabel) such as “Blue Angel” (RAL Certificate), “EU Flower” and “TCO” as well as the EU

Directives for WEEE (Waste Electrical and Electronic Equipment) and RoHS (Restriction of the Use of Hazardous Substances in Electrical and Electronic Equipment).

### Chemical resistance

The resistance of Bayblend® to chemicals is dependent, among other things, on temperature, duration of exposure and the stress condition (internal and external stresses) of the molding. For this reason, when testing the chemical resistance, it is recommended to use the test which most closely corresponds to the practical service conditions of the molding.

The test results listed in the table below were measured on parts with low stress which had been stored free of mechanical stress in the agents for 6 months at room temperature. The rating “resistant” implies that no change can be seen with the naked eye compared with the freshly molded state. For “limited resistance”, there is a definite change in the thermoplastic which results, e.g. in surface swelling, surface clouding or loss of gloss. In the case of “not resistant”, stress cracks form or the thermoplastic dissolves or starts to dissolve in the medium.

The resistance of Bayblend® moldings to water and neutral liquid media is favorable up to 40 °C. At higher water temperatures, chemical decomposition occurs (hydrolysis), the rate of which is dependent on temperature and

1. Hydrocarbons	
n-Hexane	o
Super-grade petrol containing aromatics	–
Heating oil	o
Cleaning solvent, no aromatics	o
Benzene	–
Naphthalene	–
Nitrobenzene	–
Toluene	–
2. Alcohols	
Ethyl alcohol, 96 %	o
Isopropanol	o
Phenol	–
Glycol	o
Glycerol	o
3. Ketones	
Acetone	–
Methylisobutyl ketone	–
4. Silicone oils	
Baysilon® M 300	+

5. Acids	
Hydrochloric acid, 20 %	+
Nitric acid, 10 %	+
Phosphoric acid, 30 %	+
Sulfuric acid, 30 %	+
Citric acid, 10 %	+
Lactic acid, 10 %	+
Acetic acid, 10 %	+
Oleic acid	–
6. Bases	
Aniline	–
Caustic soda, 10 %	–
Ammonia solution, diluted	–
7. Halogens	
Bromine	–
Chlorine	–
Iodine	–
8. Oils, fats	
Soy bean oil	–
Olive oil	–
Lard	–
Butter	–

9. Salt solutions	
Potassium carbonate, saturated	–
Sodium thiosulfate	+
Sodium hypochloride	+
Sea water	+
10. Cleaning agents	
Curd soap solution, 2 %	+
Detergent, Persil®	o
Cleaning agent, Dor®	+
11. Other media	
Diethyl ether	–
Urea	+
Trichloroethylene	–
Nitrobenzene	–
Hydrogen peroxide, 30 %	+

+ = resistant  
o = limited resistance  
– = not resistant

Table 1: Test results of chemical resistance of Bayblend® at room temperature

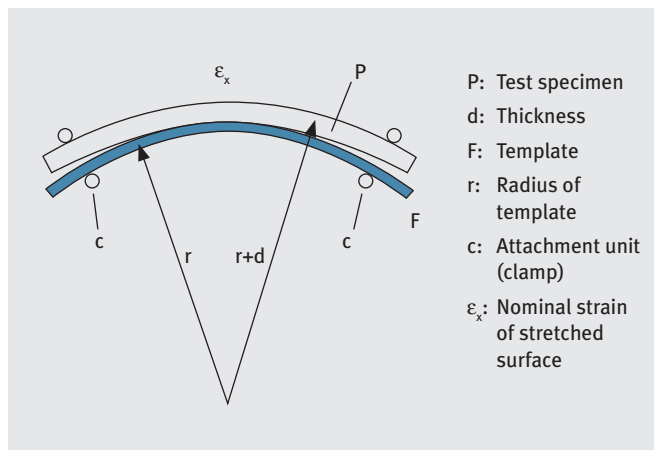

**Fig. 9: Bent strip test according to ISO 4599 to assess stress crack resistance**

time. Bayblend® moldings are therefore not suitable for use where there is permanent contact with hot water. On request, special hydrolysis-stabilized grades such as FR 3008 HR can be recommended for specific applications. At room temperature, Bayblend® parts have a similar resistance to mineral acids (including higher concentrations), numerous organic acids and liquid salt solutions as they have to water. In relation to bases, Bayblend® moldings are largely nonresistant and can degrade relatively quickly, particularly at higher temperatures. Bayblend® parts are subject to surface swelling or dissolving by aromatics, ketones, esters and chlorinated hydrocarbons. In particular, the resistance of Bayblend® to these last-named media depends on the number of functional groups in the molecule and, in some cases, on the length of the aliphatic radicals. This list can only provide an initial indication of the reaction of Bayblend® to these chemicals. Whether Bayblend® is a suitable or unsuitable material for a molded part depends on the specific conditions of the part and its intended use. Such tests are therefore normally use-specific to finished components and are carried out as the responsibility of the manufacturer or supplier of the part.

### Resistance to stress cracking

When molded parts under specific levels of tensile stress come into contact with chemicals, stress cracks can form. The assessment of chemical resistance under load will normally be made with the help of the bent strip method according to EN ISO 4599. In this method, test specimens

(80 x 10 x 4 mm rectangular bars) are stretched over metal templates with defined outer fiber strain (up to 2.4 %) and stored in the relevant medium for a given exposure time, preferably at the application temperature. Afterwards, the test specimens are examined for fractures and for visually recognizable surface changes. The results provide valuable information on the behavior of Bayblend® moldings in practice. High outer fiber strain (> 5 %) and increased temperatures should be avoided, as they promote the formation of stress cracks. The contact of low-molecular plasticizer (e.g. from PVC film) with Bayblend® moldings that are under stress, can lead to stress cracks, particularly at higher temperatures. Within the permitted outer fiber strain levels (up to 0.4 %), the Bayblend® rectangular bars generally have a noncritical response to contact with a laminated plasticized PVC film. Polymeric plasticizers have proved to be largely harmless. Brief contact with hydrocarbons (e.g. gasoline) at room temperature is relatively uncritical for Bayblend® moldings. In this case, at most, it can lead to the formation of stains on the surface of the molded parts due to swelling. Longer exposure combined with externally applied stress can result in crack formation and the degradation of mechanical properties. Experience has also shown that Bayblend® parts respond uncritically to contact with paraffin oil (aliphatic) – even over a long period. More critical are fats and oils based on fatty acid esters. Short-term contact (max. 10 min) with chlorofluorohydrocarbons does not cause a reduction in the impact strength of Bayblend® test specimens. Experience has also shown that for low-stress molded parts no stress cracks appear. For longer periods of contact, or higher outer fiber strain (> 0.5 %), material damage can be expected.

### Optical properties

Due to its rubber content Bayblend® is opaque. Therefore, only opaque colors (in a large range of shades) are available.

Using nonreinforced Bayblend® for smooth moldings will generally produce uniform, high-gloss surfaces. Surfaces with reduced gloss can be obtained with specially developed matt grades and by appropriate mold surface treatment.

### Weatherability and light resistance

The weathering of Bayblend®, as with most thermoplastics, leads to color changes and a degradation of the mechanical properties. However, the degradation in the properties remains within limits which ensure that they meet the release status, e.g. in the automotive industry.

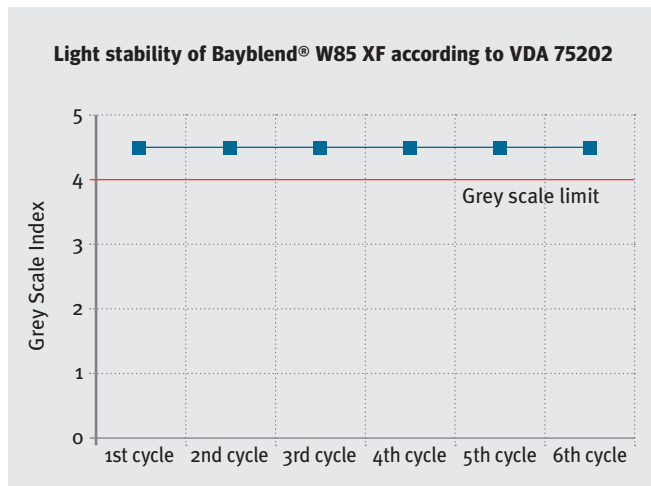

Fig. 10: Result of change of grey scale according to DIN EN 20105-A02

The globally recognized illumination standard for interior use according to OEM requirements ( housings for use in the fields of IT/DT and E&E, e.g. for monitors, printers) in accordance with ASTM D 4459 – the so-called IBM Test – with a permissible color change range for Delta E of 1.5, is generally easily achieved by Bayblend® FR.

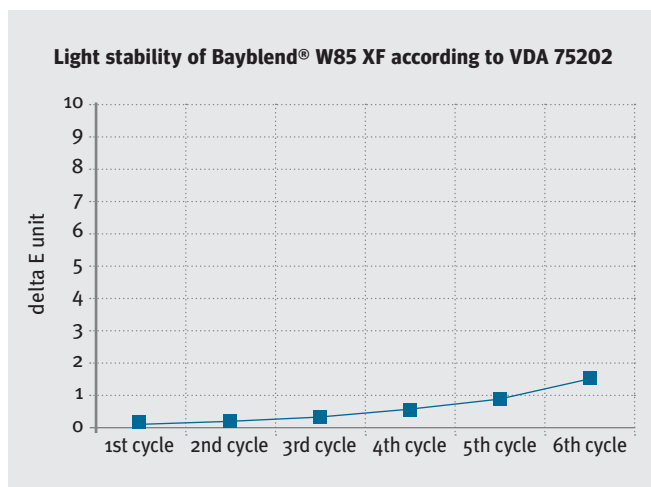

Fig. 11: Determination of change of color as delta E unit

The lightfastness of Bayblend® is determined by the proportion of ABS component. Sunlight may cause a change of color.

Special grades are available for higher weatherability requirements or, as an alternative, the molding can be painted.

### Emission characteristics

All Bayblend® grades designed for the interior of automobiles are low in emissions, i.e. the emission requirements of the European automotive industry for vehicle interior components can generally be fulfilled by these products (the majority of the Bayblend® T grades). Since the automotive industry demands an emission quantification, it should be noted that the emission characteristics are significantly influenced by the injection molding process and the molding design (particularly the gating system). Our design and process recommendations should be followed in order to achieve the optimum emission values.

## PROCESSING

Meticulous processing is essential to obtain optimum properties for molded parts.

### Processing by injection molding

Bayblend® is generally processed by injection molding.

### Machinery

All modern injection molding machines are suitable. When processing Bayblend®, it makes sense to match the size of the machine to the weight of the article. A metering path of 1 to 3 D (D = screw diameter) is recommended.

### Screw geometry

Optimum plastication has been shown to occur using a triple-zone screw with an L/D ratio of 18:1 up to 22:1 and a flight depth ratio of 2:1 up to 2.5:1. The flight depth ratio is dependent on the screw diameter. The pitch of the screw is 1 D.

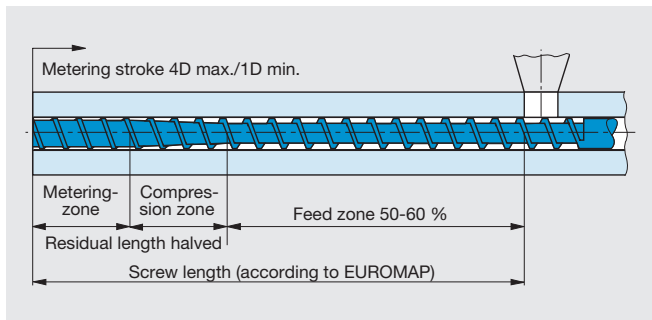

**Fig. 12: Three-zone screw**

### Nozzles

The preferred method of processing Bayblend® is with open nozzles. With shut-off nozzles, there is a risk of material damage due to high shearing, specks and malfunctions. Egress of the melt can be prevented using compression relief (screw retraction). In order to avoid demolding problems due to undercuts, the nozzle bore diameter must be 0.5 to 1 mm smaller than the bore of the sprue bush.

Open, externally heated systems are recommended for processing using hot-runner technology. It is important that the system has good flow characteristics, i.e. no “dead spots” where material degradation can occur, and that uniform temperature distribution is guaranteed.

### Nonreturn valve

The nonreturn valve should be designed such that no melt can be caught in dead spots with resulting thermal degradation.

### Drying

Bayblend® is supplied in nonmoistureproof packaging. Therefore, the granules can absorb moisture during transport and storage (approx. 0.2 % in standard atmospheric conditions). When processing Bayblend®, therefore, care should be taken to ensure that the granules are processed in dry conditions. For injection molding the residual moisture in the granules should be less than 0.02 %.

An excessive amount of moisture in the plastic melt can lead to surface defects in the form of streaks as well as hydrolytic degradation (reduction of the mechanical properties).

### Recommended drying conditions

#### Drying temperature

Depending on the grade, drying takes place at a temperature which is 10 °C lower than the Vicat softening temperature of the material (85 to max. 110 °C).

Excessive temperatures should be avoided, as otherwise the granules can become agglomerated due to the pressure from the layers of granules above, or material damage can occur.

#### Drying time

Recirculating air dryer (50 % fresh air): 4 to 8 hours

Fresh-air dryer (rapid dryer): 3 to 4 hours

Dry-air dryer (recommended): 2 to 4 hours

Excessive drying should be avoided as color changes and damage to the rubber component cannot be ruled out.

When using recirculating air drying cabinets, the fill depth of the granules should not be much more than 3 cm due to the lowered rate of air circulation.

In addition to the drying of solids described here, melt drying in the form of degassing plastication can also be used for Bayblend®. This is practiced almost exclusively in extrusion processing.

The time spent in the unheated hopper should be kept to a minimum.

As a check, a volume of material can be ejected without pressure from the nozzle of the injection molding cylinder into free air. The escaping slug of material must be smooth and free of bubbles.

#### Processing temperature

The optimum processing temperature must be determined according to grade and molding and should be between 240 and 280 °C. It is recommended that the effective melt temperature be checked using an insertion thermometer on the ejected press cake.

Overheating, or leaving the melt in the cylinder for an extended period of time, can result in material damage, i.e. a reduction in strength and/or surface defects in the form of streaks on the injection molded part. Thermal decomposition of the material starts at approx. 300 °C.

### Mold heating

In addition to the cycle time, the mold temperature has a decisive influence on the quality of the molding. Of course, low temperatures result in shorter production times, but also lead to reduced quality in the molding. The degree of orientation, the inherent stresses and the postshrinkage increase, and surface quality is reduced.

Mold heating should be uniform and should be in the recommended range of 70 to 100 °C. Grade-dependent recommendations should be followed.

### Screw speed

The screw speed should be regulated such that its circumferential speed is in the range of 0.1 to 0.3 m/s.

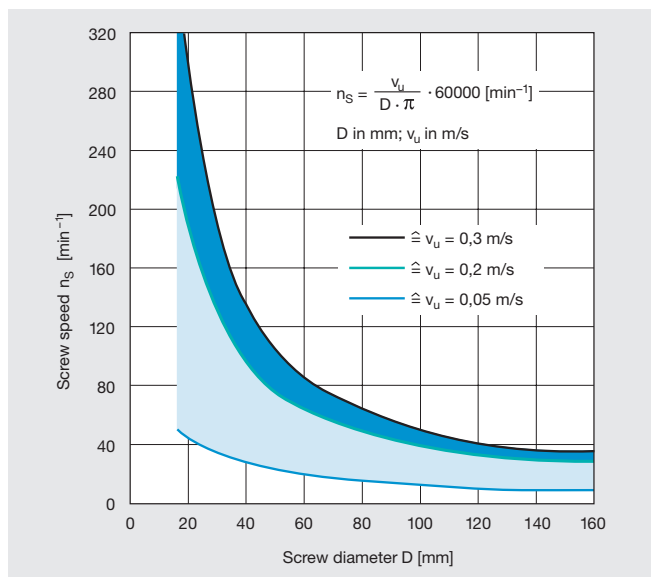

Fig. 13: Correlation between screw speed and screw diameter

## Processing pressures

### Injection pressure

The selected injection pressure should be just high enough to completely fill the mold without surface defects and flash formation. Specific injection pressures from 800 to 1200 bar are the general rule.

### Injection speed

Processing should be carried out using a medium injection rate. For very high-volume moldings, it is recommended to use a slower injection speed, since this will help to achieve a uniform mold fill. For geometrically very complex molded parts (gate position, wall thickness distribution) it may be necessary to use staged injection speeds.

### Holding pressure

The holding pressure performs the task of compensating for the material shrinkage during the cooling down phase. It will generally be in the range of up to 50 % of the injection pressure. A timely changeover from injection pressure to holding pressure prevents overinjection. In order to obtain low-stress molded parts, the holding pressure should be set just high enough to prevent voids and sink marks. The holding pressure time should remain effective until the sprue has solidified into shape. The optimum holding pressure time can be determined by comparing the weight of the moldings.

### Back pressure

A back pressure of approx. 50 to 100 bar is specifically recommended. The back pressure serves to ensure that the air drawn in during metering is displaced in good time.

### Demolding behavior

The demolding behavior of a part is influenced by the surface roughness of the mold walls, the stress condition (shrinkage) in the mold voids, and the shape of the molding. The adhesion of the molding to the mold core depends essentially on the processing conditions (pressure conditions, mold wall temperatures). By using a sufficient number of ejector pins, and giving consideration to the

draft angles, Bayblend® can generally be demolded without difficulty. For very critical moldings, it is possible to use an external release agent.

### Shrinkage

Besides the part geometry, shrinkage depends primarily on the magnitude of the holding pressure and its duration, as well as the melt and mold temperature and the prevailing cooling conditions in the mold .

The molding shrinkage of nonreinforced Bayblend® (measured on test specimens in accordance with ISO 2577) lies mainly in the range of 0.5 to 0.75 %. Since the shrinkages parallel and transverse to the direction of flow are practically identical, the manufacture of warp-free molded parts is possible. In the glass fiber-reinforced Bayblend® grades, the molding shrinkage is less than that of the comparable nonreinforced grades. In this case, it is in the range of 0.2 to 0.6 %, depending on the glass fiber content. The orientation of the glass fibers creates a differential in the shrinkage parallel and transverse to the direction of flow. Postshrinkage depends essentially on the storage temperature and time. It is considerably less than that of semi-crystalline materials and is generally less than 0.1 %.

Because of the large number of possible influences on shrinkage, it is very difficult to give more accurate data on process shrinkage. Therefore, for moldings with very tight dimensional tolerances, it is recommended to set the mold dimensions such that it is still possible to make a correction after initial mold proving.

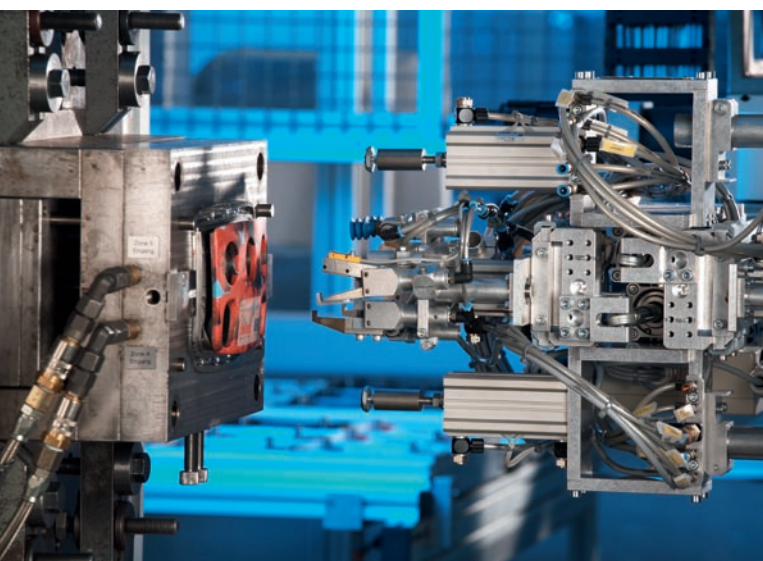

### Change of material, cleaning and production stoppages

Bayblend® must only be processed on machines which are free of any foreign materials.

When changing materials, spray the plasticating cylinder until it is empty and then purge it using the new material or a combination of the new material and a cylinder cleaning agent. If a color change is made, try if possible to go from a light color shade to a darker one. In special cases (e.g. changing from a high-viscosity to a very low-viscosity material) clean the plasticating unit.

When cleaning prior to a change of materials, if the contamination of the plasticating unit is not particularly obstinate, proceed as described for a material change. Stubborn contamination can be removed as follows: first clean the plasticizer unit with cylinder cleaning agent and, if necessary, purge with high-viscosity PE or PP. Disassemble the unit and clean the components while they are still hot, using a steel brush, and repolish them with rags and polishing paste. Do not use sandpaper! Alternatively, the dismantled components can also be cleaned in aluminum oxide whirlpools, oil baths and suitable solvent baths (if necessary, ultrasonically assisted). Subsequent “blasting” with glass or steel balls damages the surface of the steel parts.

After brief breaks in production (up to 15 minutes), the melt remaining in the cylinder should be repeatedly ejected until a visually perfect strand of material is obtained. During longer breaks (longer interruptions and weekends, shutdown for several weeks) the plasticating unit should be spray-cleaned, the screw driven to its fully forward location and the machine and heating turned off.

### Other injection molding processes

In addition to the standard injection molding process described here, Bayblend® can also be processed using gas-assisted and two-component injection molding processes, or in-mold-decoration (IMD). Information on these technologies is readily available on request.

### Extrusion, extrusion blow molding

Bayblend® is well-suited for processing by extrusion. The normal processes are sheet extrusion, profile extrusion and extrusion blow molding.

Special-purpose Bayblend® grades which have been optimized to meet extrusion requirements are available.

### Preparation/Predrying

In the extrusion of Bayblend®, processing on degassing extruders (vacuum degassing) has become established. If no degassing extruders are available, Bayblend® must be predried. Insufficient predrying leads to small bubbles and streaks or the formation of streaks on the extrudate. With regard to drying of the granules, the same conditions apply as for injection molding.

### Extruders

Bayblend® is best processed on single-screw extruders. It is advisable to equip the screw with a mixing element located at the end of the metering zone.

### Extruder temperature control

The temperature characteristics must be matched to the extrusion machine and the particular processing method. Sheet extrusion requires higher temperatures than methods such as profile extrusion. The preferred melt temperature is in the range of 240 to 270 °C.

### Calender stack temperature control

The roll temperatures to be selected are primarily dependent on the construction of the calender, the sheet thickness and the throughput of the extruder. Therefore, precise data are not possible.

The following can be used as guide values for processing on a calender with vertical roller arrangement (melt infeed in the lower roller gap):

Upper roller: 110-130 °C

Middle roller: 115-135 °C

Lower roller: 110-120 °C

### Subsequent treatment and hot forming

Forming of sheets with Bayblend® is possible using all of the known thermoforming processes. In principal, the thermoforming process takes place under the same conditions as for ABS sheet forming, however, at higher temperatures. Ideal sheet temperatures are in the range of 170 – 190 °C. Extruded sheets that are to be stored for a long period

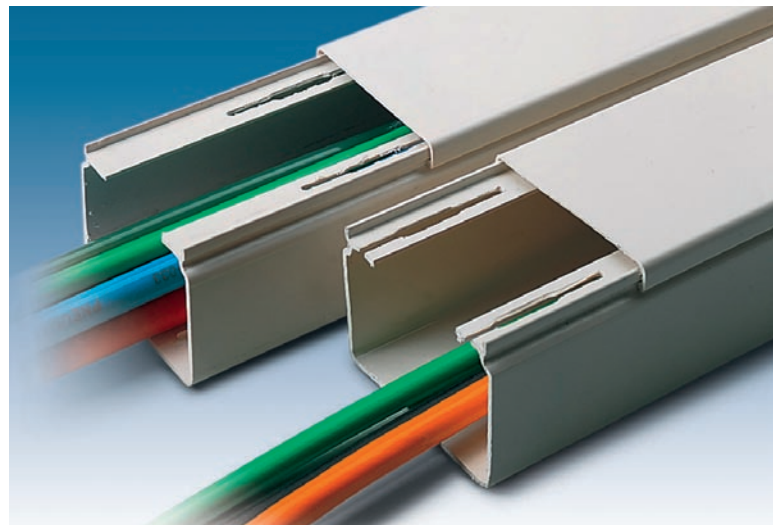

without sufficient protection against moisture must be predried. Depending on the grade of Bayblend®, the drying temperatures are between 85 and 110 °C. The drying time is dependent on the thickness of the sheets.

### Blow molding

Some Bayblend® grades are suitable for extrusion blow molding. Particularly worthy of mention are the grades T65 HI and FR 3030, which, because of the high stability of the melt, are especially suitable for large moldings with good surface quality.

Since degassing screws are not usual in extrusion blow molding equipment, predrying is essential (analogous to the injection molding process).

For a high melt stiffness, the melt temperature should be set low; typically in the range of 215 – 270 °C. Mold temperatures of 40 – 60 °C have proved to be advantageous.

In order to obtain a smooth surface finish on the product, the nozzle should be precision-ground and the melt discharge passage preferably polished. Special surface coatings are not required.

Grooved feed zones can lead to overloading of the motor. In such a case, the temperature of the grooved bush should be raised as much as possible, ideally to 110 – 130 °C.

### Processing regrind

As a general recommendation, carefully prepared 100 % regrind should preferably be used for parts where the demands on stability levels are not so high. A single addition of up to 20 % regrind to virgin material is also possible.

Suitable production scrap includes: sprues and cold runners; incompletely molded parts or mechanically damaged parts which are essentially new. All of the scrap must be free from overheating effects, moisture streaks and contamination. The powder content in the regrind must be less than 10 %.

Even carefully prepared regrind does not have the level of properties of virgin material. Therefore, regrind, or products with regrind content, cannot form the subject of complaints.

The instructions in the safety data sheets should be followed. These can be sent on request.

## SECONDARY FINISHING

Complete and semifinished molded parts made from Bayblend® are well-suited for manual or machine finishing.

### Machining

Bayblend® is easy to saw, drill, turn, file and mill. In order to guarantee a long tool life, the use of tungsten carbide-tipped tools is recommended. This is particularly relevant when machining glass fiber-reinforced products. During the machining process, care must be taken to ensure that the temperature at the point of machining does not exceed the softening temperature of that particular product, as the material may smear or decompose. Adequate cooling with water or air must be ensured. The cutting parameters must be selected to provide small feed rates at high cutting speeds.

### Painting

Bayblend® moldings are well-suited for painting. To ensure a good paint finish, the surfaces must be clean, i.e. free of dust or grease. Particularly good adhesion is achieved using polyurethane-based coating systems. Unsuitable combinations of solvents in the paint system can attack (PC+ABS) blends and, depending on the stress condition

of the molding, may initiate stress cracking. It is therefore recommended to contact the paint manufacturers who can supply suitable paint systems especially for (PC+ABS) blends. The names of these manufacturers are available on request.

In order to maintain the good toughness of Bayblend®, care should be taken to use the paint system which has the best elasticity properties.

### Printing

Printing on Bayblend® is possible with commonly used printing processes such as tampon printing and screen printing, as well as transfer printing and the thermal diffusion process. Hot foil stamping process is also possible with Bayblend®. Special inks suitable for laser printing have been developed.

### Metallizing

Bayblend® can be metallized by deposition of a metallic layer in a high vacuum or by electroplating.

In the metal deposition process, the best adhesion is achieved with aluminum, tin and copper. As protection for the very thin layer of metal, a coating of paint on the molding is recommended.

In the case of electroplating, Bayblend® grades with a high rubber content (T45 PG, T65 HI) are particularly suitable, since these offer the best adhesion. Moldings which are to be electroplated should be produced with the lowest possible stress. The etching temperature and time must be adapted to the particular molding.

### Bonding

Bayblend® moldings can be bonded not only to one another, but also to other materials. This is possible using suitable adhesive glues or diffusion adhesive. Before gluing, greases and other foreign materials must be removed from the surfaces to be glued. Dry-cleaning fluid or similar cleaning agents, which do not damage the material, can be used to remove grease. Roughening and subsequently cleaning the surfaces improves glue adhesion.



In the case of adhesive glues, two-component adhesives based on epoxy and silicone resins and polyurethanes have proved excellent. Also suitable are hot-melt adhesives and adhesives based on cyanoacrylate.

For diffusion gluing with pure solvent, 1,3-dioxolane can be used. Solvent-based adhesives can also be used. For this purpose, an 8 % (approximate) solution of polycarbonate in 1,3-dioxolane is made. After bonding, ensure adequate flash-off of the solvent from the molded part.

In designing the gluelines, care is required to ensure that there are no peel forces in the event of loading. Shear forces (tensile or compressive) are much less critical. The names of manufacturers of adhesive systems suitable for use with Bayblend® are available on request.

### Welding

Bayblend® moldings can be joined together by ultrasonic, vibration, friction, hot plate or laser welding.

In order to achieve the best possible component quality when using ultrasonic welding, it is important to ensure a correctly formed weld seam.

## MOLDED PART DESIGN

If the molded part is to embody the excellent properties of Bayblend®, then in addition to processing, part design is also of critical importance. The designer must ensure that the part has the correct dimensions, and that the design is suitable for the specified production process. In addition to the generally known guidelines for the design of injection molding parts (see VDI 2006 – Guidelines 2006), the designer must take into account the characteristics of the material and the selected grade when configuring the components.

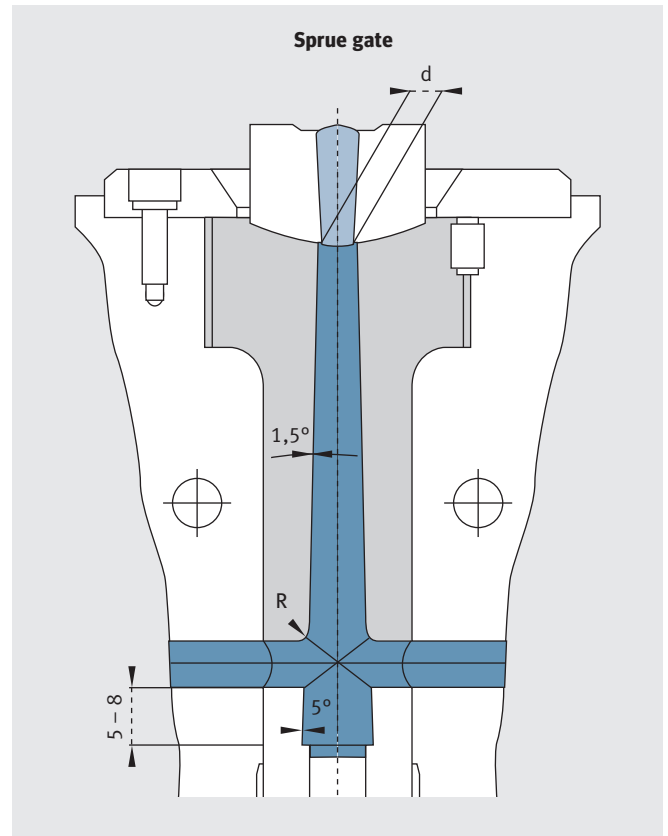
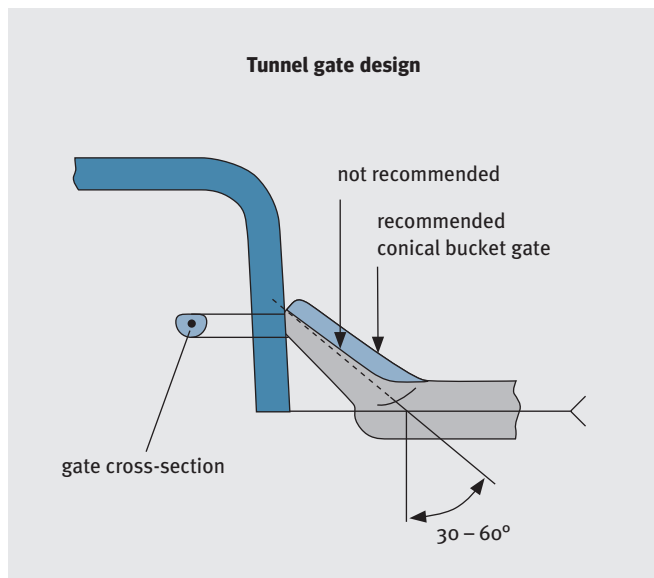

Fig. 16: Sprue bush design (sprue gate)

### Gate design

Depending on the requirements of the finished parts and the mold, all of the known types of gate such as sprue, point, tunnel, film, cone or ring can be used. The type and size of the gate are determined by the geometry of the molding. The gate must be arranged such that during the injection process the melt meets an impact wall, so that a laminar flow develops in the mold cavity, thus preventing a jet of melt. In addition, the flow paths should preferably be of equal length in order to ensure uniform material flow. The location of the gate should be chosen such that the weld lines are not situated at areas of high mechanical loading. The cross-sections of the runners and gate should have the largest possible dimensions in order to minimize the shear load on the material and pressure loss in the mold. A design with a conical bucket gate is recommended for tunnel gates.



**Fig. 17: Recommended design for a tunnel gate**

For multiple gates, the runners should be designed so that all the flow paths (and pressure drops) to the individual cavities are the same, allowing all of the cavities to be filled uniformly. A rheological calculation is recommended in order to ensure optimum matching of the diameters of the runner system (hot and cold).

### Wall thickness

The wall thickness depends on the requirements of the molding as well as the material to be used for the molding. It should be as thin as possible and as thick as necessary. It is important that wall thicknesses should be as uniform as possible and that there are no abrupt changes. Variations in wall thickness and material buildup should be avoided since these can lead to cavities, sink marks, warping and extended cycle times.

### Ribbing

In order to increase the stiffness, appropriate ribbing is considerably more effective than increasing the wall thickness. Increased stiffness is achieved only when the height of the ribs is 5 times that of the rib width. In order to avoid sink mark areas when using Bayblend®, a ribwidth/wall thickness ratio of 1:2 must be maintained.

### Radii

Due to the notching effect, sharp internal corners on molded parts promote the mechanical failure of the molding as a result of stress crack formation. Radii as small as 0.5 to 1 mm give excellent results.

### Draft angles

In order to facilitate easy demolding of injection-molded parts, an appropriate draft angle is required in the direction of demolding. These draft angles are dependent on a number of factors, e.g. the depth of the part to be demolded, the wall thickness, surface roughness and the rigidity of the mold. For Bayblend® parts with smooth surfaces a draft angle of 1° is sufficient in most cases. It may be necessary to increase the draft angle for very complicated molded parts and textured surfaces.

### Holes and openings

In order to avoid the risk of breakout, holes and openings must not be placed close to the edge of the molding. The reduced strength of weld seams must also be taken into account.

### Snap-fits

In the case of snap-fits, it should be noted that the permitted strain for a momentary one-off joining procedure with nonreinforced Bayblend® must not exceed 3.0 %. If this is a frequently repeated procedure, the value is approx. 1.8 %.

### RECYCLING

Part labeling is in accordance with DIN EN ISO 11469. Further details can be found in our technical information leaflet PCS-1164.

After use, single-sort, noncontaminated moldings made from Bayblend® can be recycled. Contaminated moldings can be recycled chemically or thermally.

This information and our technical advice – whether verbal, in writing or by way of trials – are given in good faith but without warranty, and this also applies where proprietary rights of third parties are involved. Our advice does not release you from the obligation to check its validity and to test our products as to their suitability for the intended processes and uses. The application, use and processing of our products and the products manufactured by you on the basis of our technical advice are beyond our control and, therefore, entirely your own responsibility. Our products are sold in accordance with the current version of our General Conditions of Sale and Delivery.

Unless specified to the contrary, the values given have been established on standardized test specimens at room temperature. The figures should be regarded as guide values only and not as binding minimum values. Please note that, under certain conditions, the properties can be affected to a considerable extent by the design of the mold/die, the processing conditions and coloring.

Under the recommended processing conditions small quantities of decomposition product may be given off during processing. To preclude any risk to the health and well-being of the machine operatives, tolerance limits for the work environment must be ensured by the provision of efficient exhaust ventilation and fresh air at the workplace in accordance with the Safety Data Sheet.

In order to prevent the partial decomposition of the polymer and the generation of volatile decomposition products, the prescribed processing temperatures should not be substantially exceeded.



**Published by:**  
Bayer MaterialScience AG  
Business Unit Polycarbonates

Bayer MaterialScience AG  
51368 Leverkusen  
Germany

[www.bayermaterialscience.com](http://www.bayermaterialscience.com)



**BAYBLEND®**